

I N S T E N[®]



On/Off Outlet
Owner's Manual

Contents

Getting Started

Insteon Wall Outlet	4
On/Off Outlet	
Buttons	
Tools Needed for Installation	
Disconnect Power	

Installation Timeline

Installation	6
--------------	---

Installation Diagrams

End-of-Run Outlet	10
Middle-of-Run Outlet	11
Switched Outlet	12

Insteon Links

Understanding Linking	15
Adding to the Insteon Hub	17

Software-Only Features

Beep on Button Press	19
Blink on Traffic	
Disable Local Programming	
Error Blink	
LED Brightness	20

Local Programming

Flow Chart	23
LED Brightness	24
RF Beacon	
Load Sense	25
Soft Factory Reset	26

Factory Reset

Factory Reset	28
---------------	----

Appendix

Specifications	30
Troubleshooting	33
Certifications and Warnings	35
Product Warranty	36

Getting Started

Everything you need to quickly get up and running.

Insteon Wall Outlet

On/Off Outlet

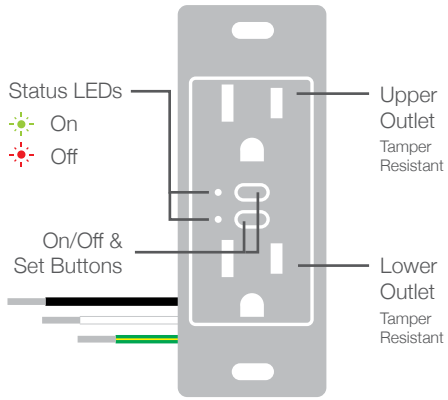

Buttons



Tap to turn the upper outlet on or off. See sections on Basic Linking and Local Programming for additional set button functions.



Tap to turn the lower outlet on or off. See sections on Basic Linking and Local Programming for additional set button functions.

Tools Needed for Installation



Phillips Screwdriver



Flathead Screwdriver



Voltage Detector



Wire Cutter / Stripper

Disconnect Power

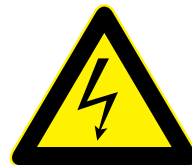

Always disconnect power before installation. Contact Insteon Support when uncertain about installation.

1-866-243-8022

Installation Timeline

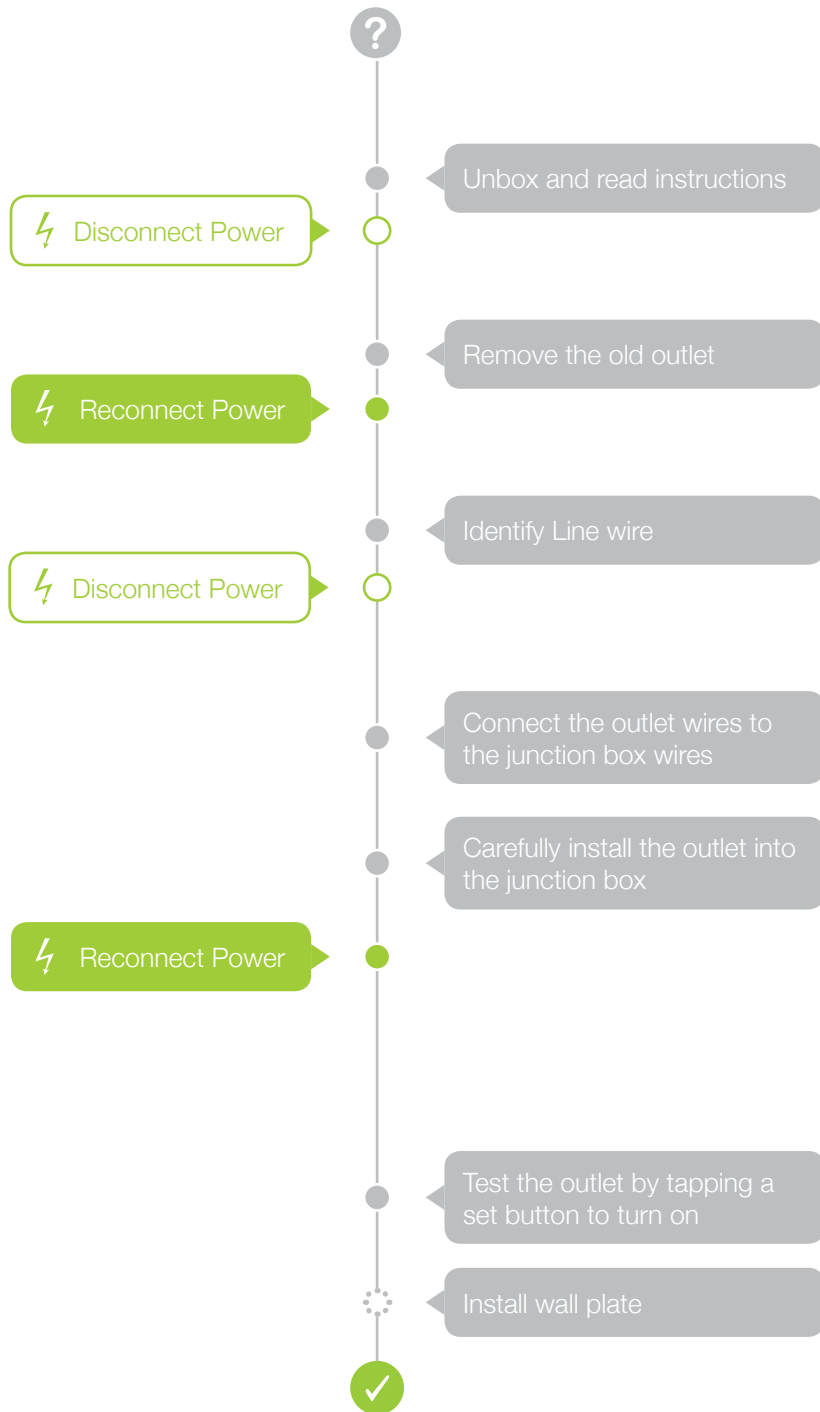

Installation

Disconnect Power

- 1 Turn off power to your outlet at the electrical service panel.

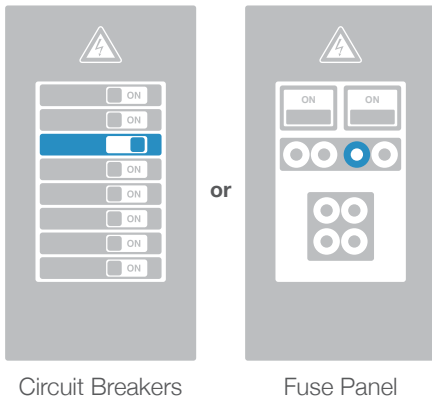

Remove the Old Outlet

- 2 Remove the old outlet and disconnect the wires.

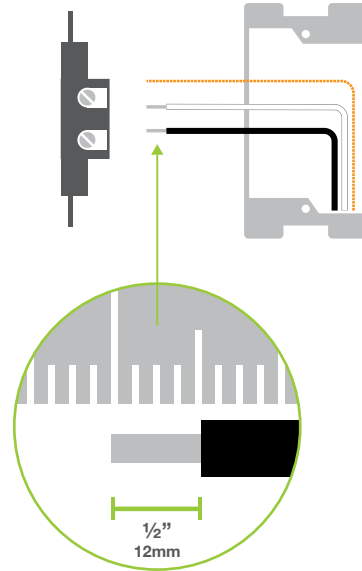

Reconnect Power

- 3 Turn on power at the circuit breaker.

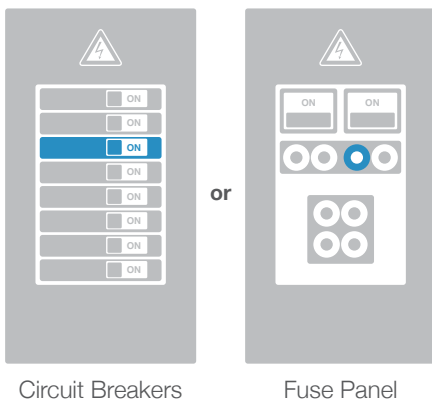

Identify Line

- 4 Use a voltage detector to identify the line wire. Line will be energized.

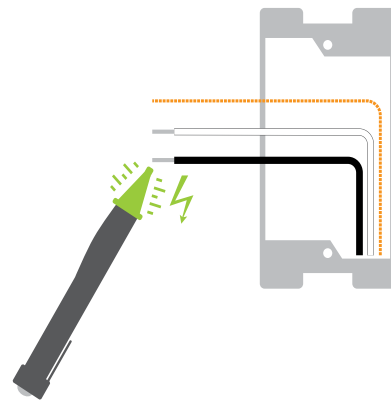

Installation

Wire-In the Outlet

- 5 Turn off power at the circuit breaker. Connect the Outlet wires to the identified wires in the junction box. Verify that the wire nuts are secure and that no exposed copper wire is visible. Additional wiring diagrams can be found in the Installation Diagrams section.

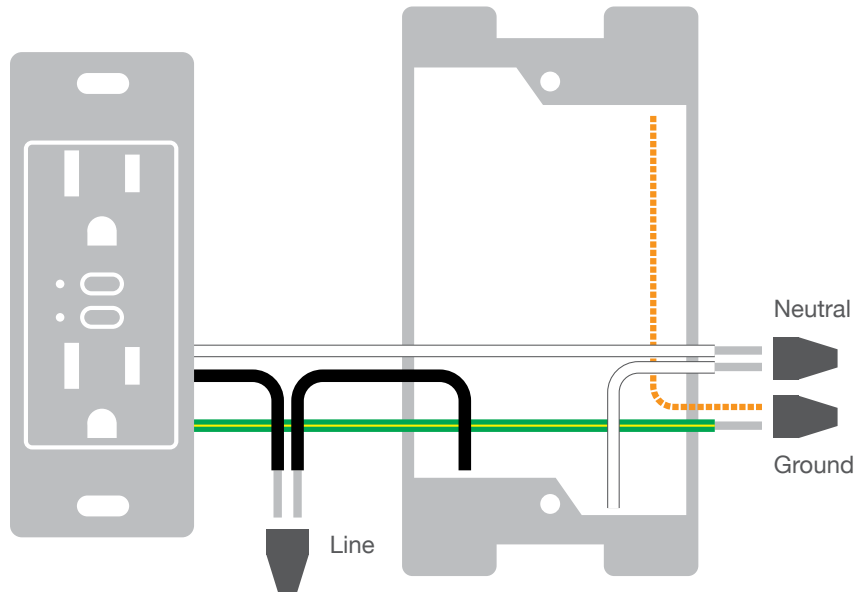

Install the Outlet

- 6 Mount the Outlet into the junction box.

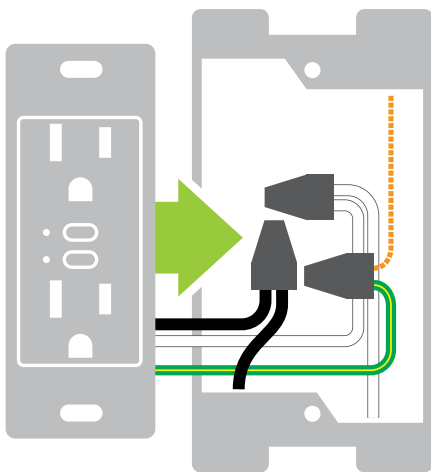

Reconnect Power

- 7 Turn power on to the outlet at the circuit breaker panel.

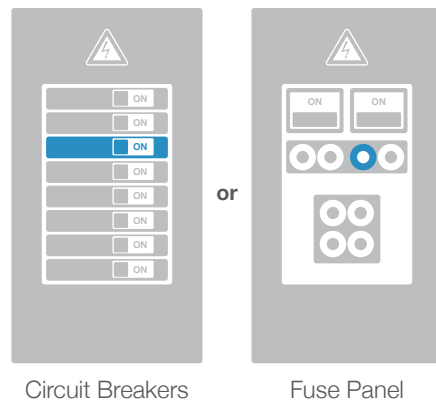

Installation

Test the Outlet

- 8 Test your Outlet by tapping one of the set buttons to turn On and Off.

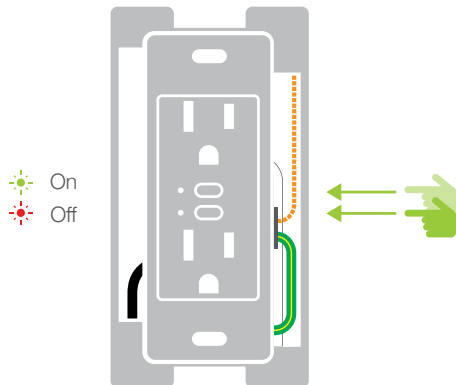

Install Wall Plate

- 9 Complete installation by reattaching your wall plate. For the best look, use an INSTEON Screwless Wall Plate.

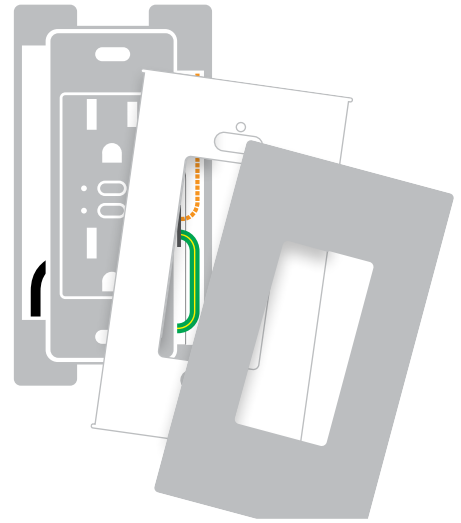

✓ Installation of your Wall Outlet is now complete.

Installation Diagrams

Use the installation diagrams in this section to help you wire your Wall Outlet.

End-of-Run Outlet

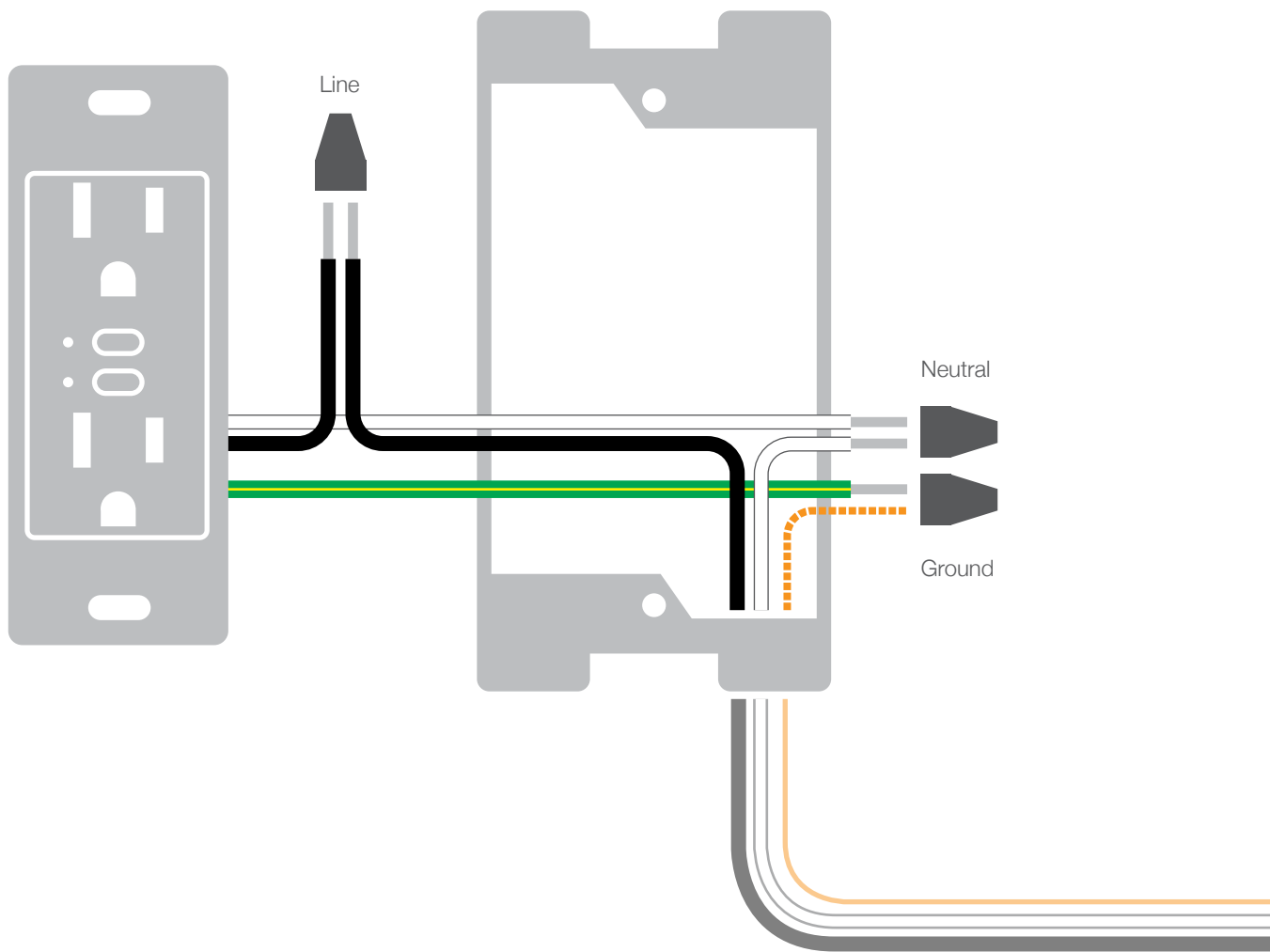

Middle-of-Run Outlet

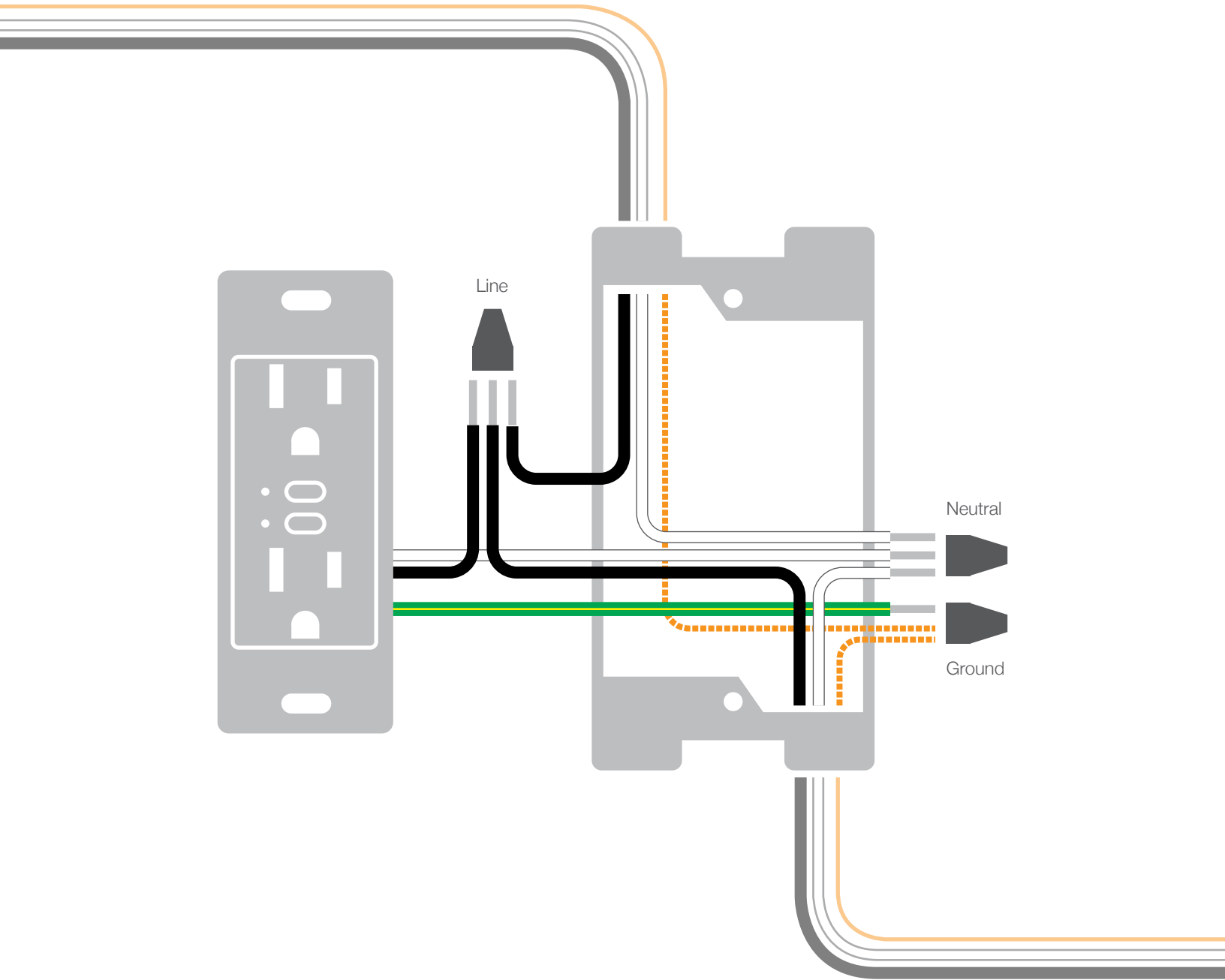

Switched Outlet

Without Insteon Wall Switch

Replacing a switched outlet requires removing the wall switch from the circuit. The wall switch can be replaced by an Insteon Wall Switch or Keypad if control is still desired.

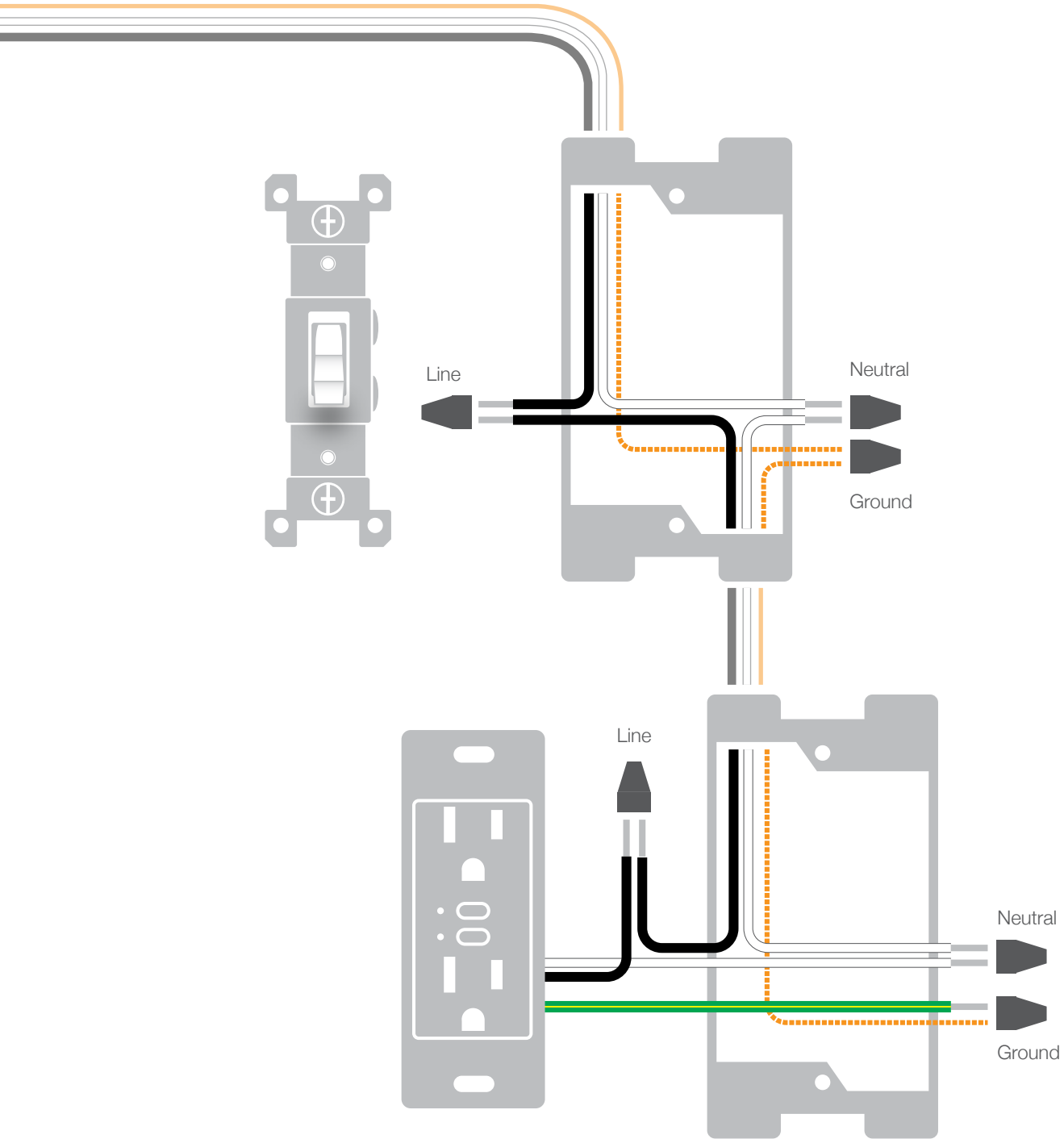

Switched Outlet

With Insteon Wall Keypad

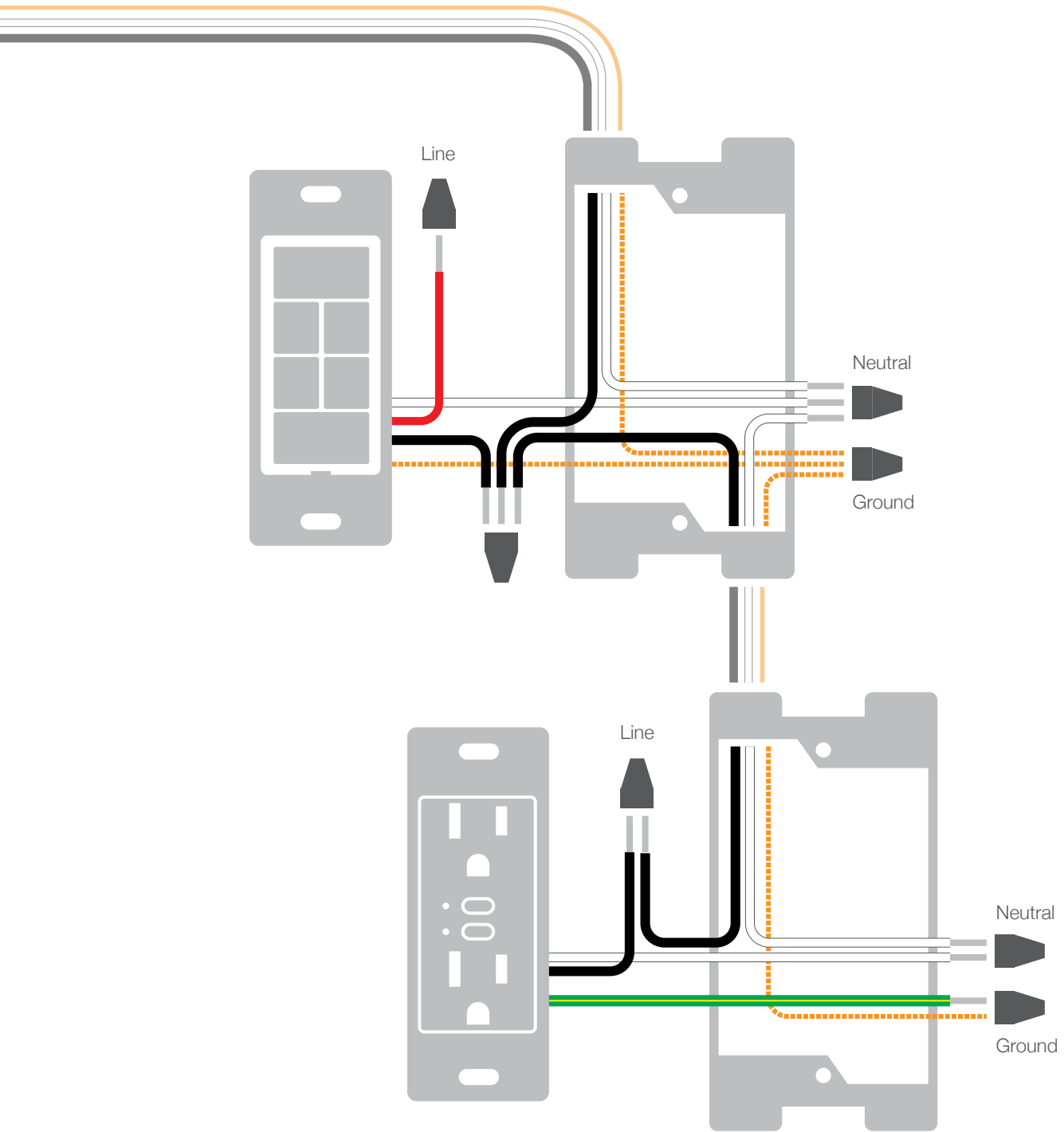

Insteon Links

Insteon devices can stand alone and function as a local switch or dimmer, but their real power comes when they are connected together to form a control system. Most Insteon devices can control one another and be the recipient of control. The process of associating multiple Insteon devices to one another is called Linking.

Understanding Linking

Links are One-Way

When linking Insteon devices, the links that are created are one-way.

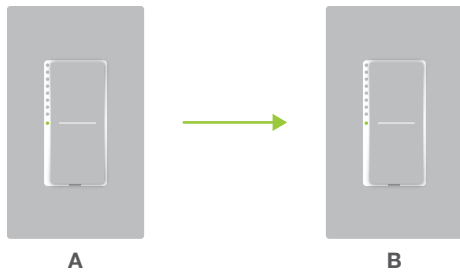

Switch A will turn Switch B on and off but Switch B cannot turn Switch A on or off.

Links Remember a Device's State

The current state of the controlled device is stored in the link: On, off or dimmed.

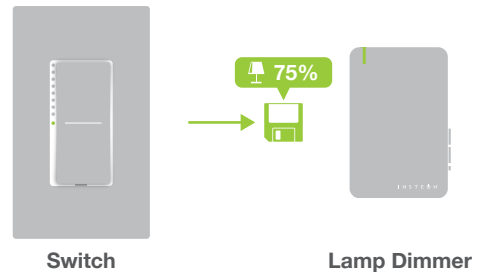

The switch will turn on the Lamp Dimmer to 75% brightness.

Controllers

Insteon devices that can turn other devices on or off are called controllers.

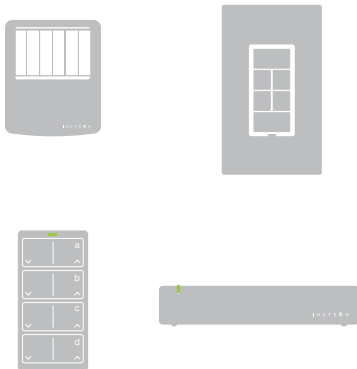

Sensors, Switches, Keypads and the Hub are common controllers.

Responders

Insteon devices that receive the command of a controller are called responders.

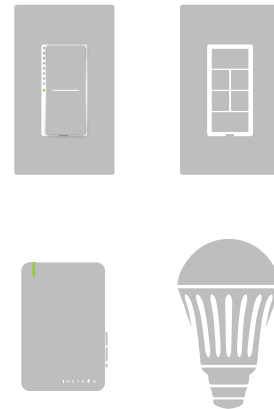

Switches, Keypads, Plug-In Modules and LED Bulbs are common responders.

Understanding Linking

Controller-Only

Some devices, like sensors, can only control other devices.

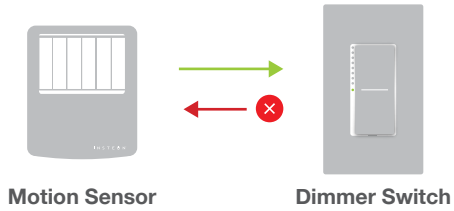

The Motion Sensor will turn on the Switch but the switches cannot control the Motion Sensor.

Responder-Only

Some devices cannot control other devices; these devices only receive Insteon commands.

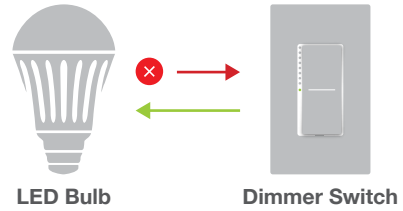

Some devices can only link as responders to devices and scenes.

Grouping Devices

You may want to group together two devices, for example, in a virtual-three way configuration. For Insteon, this is called Cross Linking.

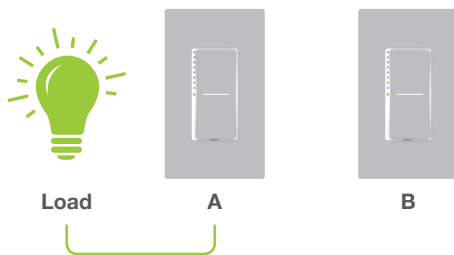

To mirror Switch A and B so that they each control one another and the connected load, Cross Linking is necessary.

Use Cross Linking

To Cross Link, simply turn on the devices and perform the linking process twice, once in each direction.

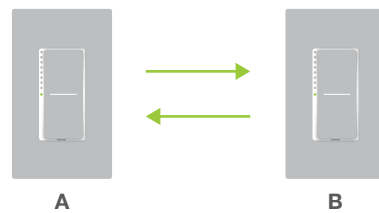

Link Switch A to Switch B and repeat to link Switch B to Switch A.

Adding to the Insteon Hub

- 1 Tap the Add a Device button.

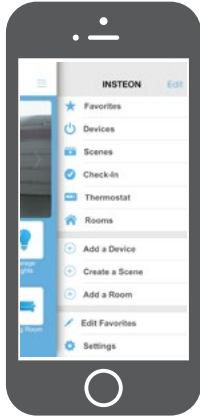

iOS

Open the drawer by swiping from the right side of your iOS device

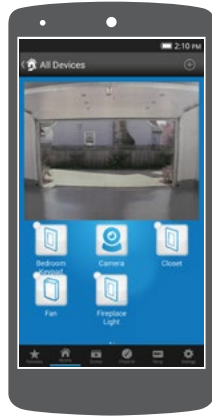

Android

Navigate to All Devices from Rooms on your Android device

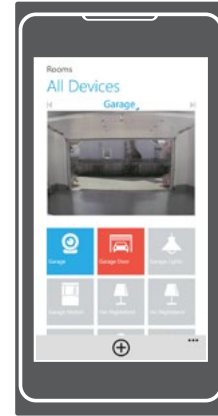

Windows Phone

Navigate to All Devices from Rooms on your Windows Phone device

- 2 When prompted, press and hold one of the set buttons on your Wall Outlet until the device beeps.

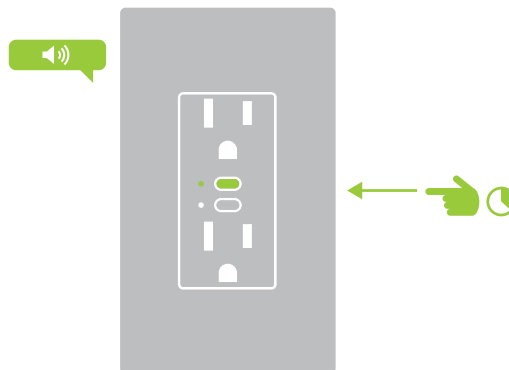

✓ Your Wall Outlet is now added to your Insteon Hub.

Software-Only Features

Most Insteon devices contain features that can only be enabled, disabled or modified using Insteon control software such as HouseLinc and an Insteon PowerLine Modem.

Software-Only Features

Beep on Button Press

The Wall Outlet will beep every time one of its buttons are tapped. By default, this feature is disabled.

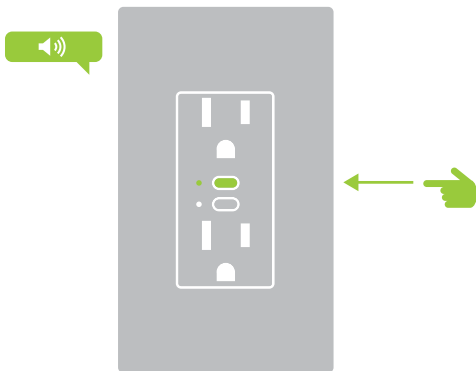

Blink on Traffic

The Wall Outlet LED will blink if it detects Insteon communication. By default, this feature is disabled.

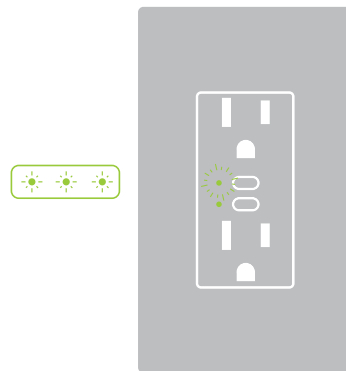

Disable Local Programming

Prevents changing any settings using the set button or tap-and-hold programming.

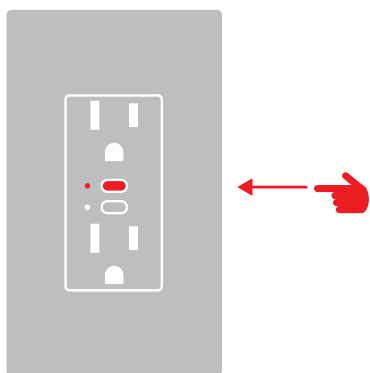

Error Blink

The Wall Outlet LED will blink red once if one or more responders do not acknowledge a message and will blink green once if all responders successfully acknowledge a message. By default, this feature is enabled.

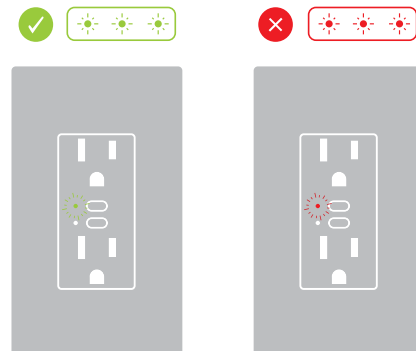

Software-Only Features

LED Brightness

Adjust the brightness of the status LEDs from full bright to off.

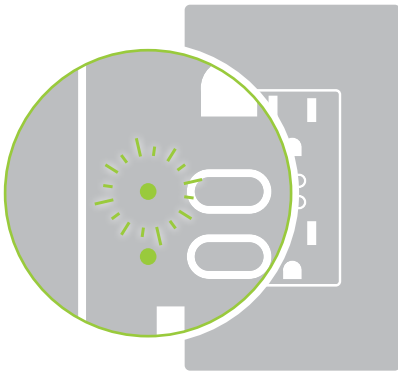

Local Programming

Encompassing all on-device programming options, use the local programming to set local properties and factory reset. For the best experience, use software for managing device properties.

Navigating the Chart

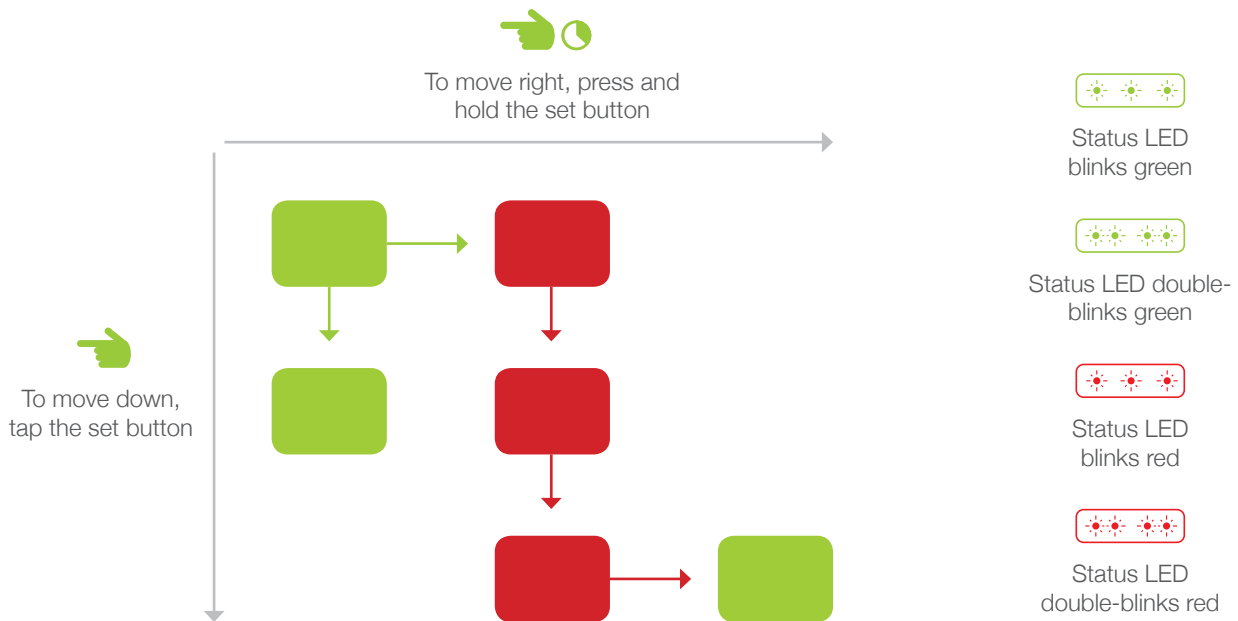

Features

Linking Mode	Readies the module for linking to another Insteon device. As linking is directional, the first device placed into linking mode will become the controller in the controller/responder relationship. The second device will become the responder. The device automatically exits linking mode after a link has been made with another Insteon device.
Multi-Linking Mode	Readies the module for linking to multiple Insteon devices. The device will remain in linking mode for 4 minutes or until the device's set button is tapped. This mode is very usefully for manually creating scenes.
Unlinking Mode	Allows the removal of links from the Insteon device. The device will automatically exit unlinking mode after a link has been removed from another Insteon device.
Multi-Unlinking Mode	Allows the removal of multiple links from the Insteon device. The device will stay in unlinking mode for 4 minutes or until the device's set button is tapped.

Flow Chart

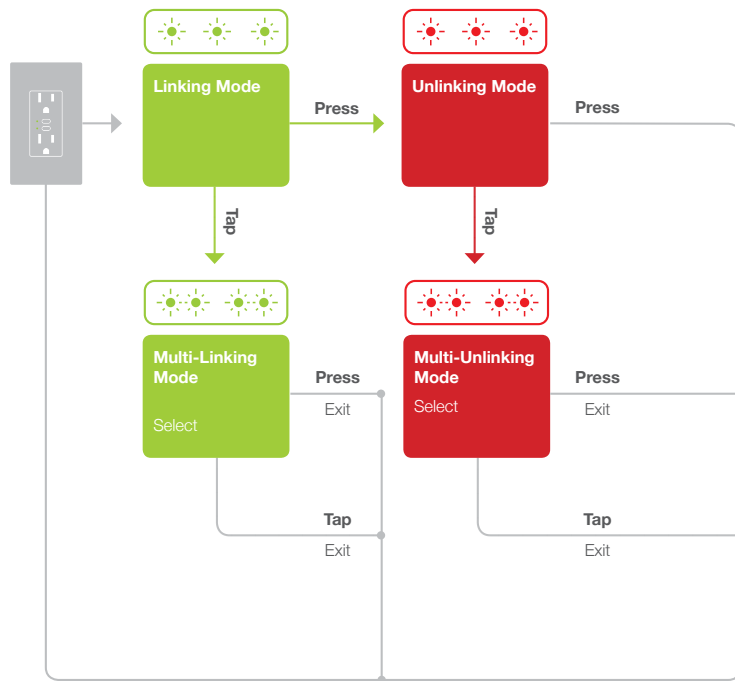

LED Brightness

Upper set button only

For a **bright** status LED, make sure the upper LED is green.

 Bright

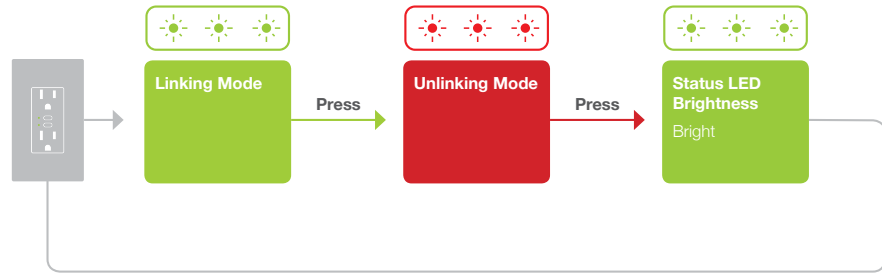

For a **dim** status LED, make sure the upper LED is red.

 Dim

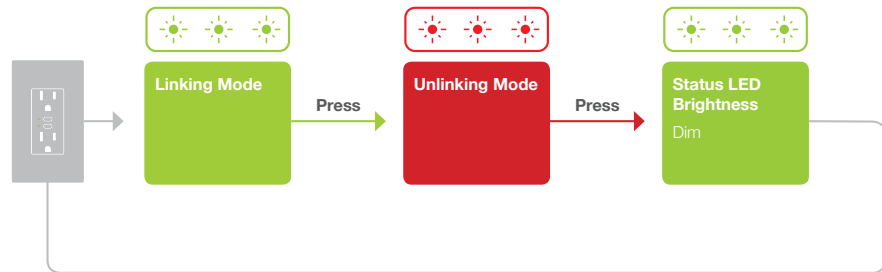

RF Beacon

Upper or lower set button

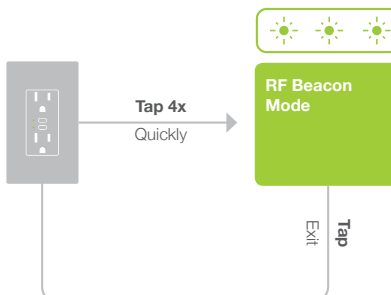

Load Sense

Enable

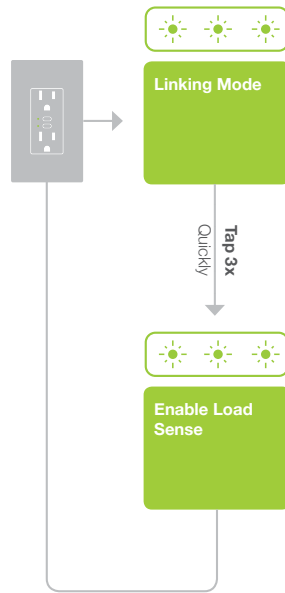

Load Sense

Disable

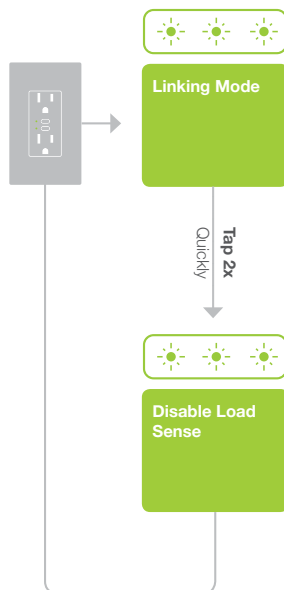

Soft Factory Reset

Upper and lower set buttons

A Soft Factory Reset will erase all device settings including any links made with the top and bottom outlets. If On/Off Outlet does not respond, attempt the Alternate Factory Reset.

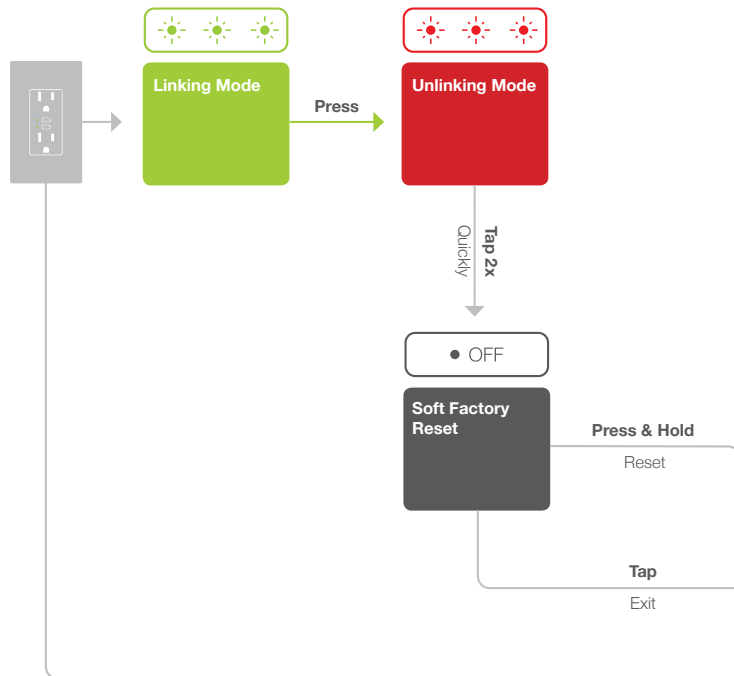

Factory Reset

A factory reset will erase all links stored in the device's database as well as any customized properties.

Factory Reset

Alternate Procedure

- 1 Factory Reset will erase all device settings including any links made with the top and bottom outlets
Turn off power to your outlet at the electrical service panel.

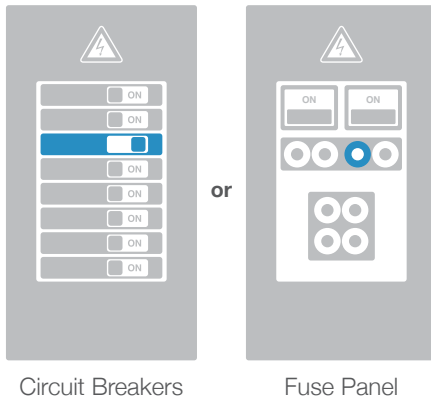

- 2 Press and hold the upper set button.

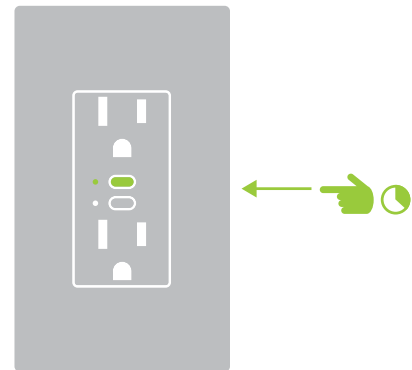

An assistant will be required to turn power on and off at the service panel.

- 3 Have your assistant turn power on to the outlet at the circuit breaker panel while continuing to press and hold the set button.

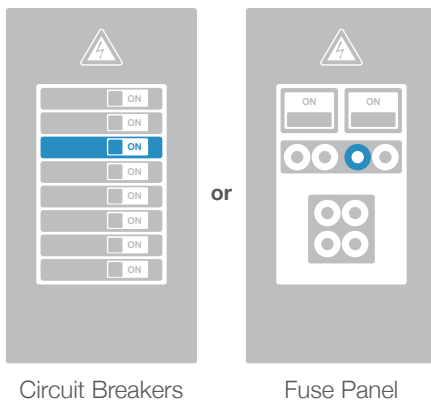

- 4 Wait for the Outlet to emit a long beep. When the beep ends, release the set button. The switch will double beep.

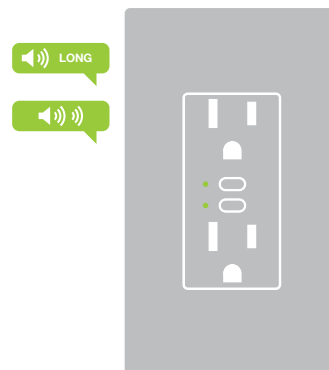

✓ Your Wall Outlet has been restored to factory settings.

Appendix

Everything else you might need to know about your Insteon product.

Specifications

General

Brand:	Insteon
FCC ID	SBP26632
Industry Canada	5202A-26632
Manufacturer Product No.:	2663-222 White 2663-223 Ivory 2663-224 Almond 2663-225 Light Almond 2663-226 Black 2663-227 Brown 2663-228 Grey
Patent No.:	Protected under US and Foreign Patents (see www.insteon.com/patents)
UPC:	813922013801 White 813922013818 Ivory 813922013825 Almond 813922013832 Light Almond 813922013849 Black 813922013856 Brown 813922013863 Grey
Warranty:	2 years, limited

Operation

Local Control	Yes
Setup Memory	Non-volatile EEPROM
Status LED	Red/Green LEDs

Insteon Features

Insteon Device Category	0x02
Insteon Device Subcategory	0x39
Insteon ID	1
Insteon Links	417
Insteon Messages Repeated	Yes
Insteon Minimum Receive Level	10 mV
Insteon Minimum Transmit Level	3.2 Vpp into 5 Ohms

Insteon Powerline Device	Yes
Insteon Powerline Frequency	131.65 KHz
Insteon RF Device	Yes
Maximum Controlled Scenes	400
Maximum Scene Memberships	400
RF Beacon	Yes
Radio Frequency	915.0 MHz US/Canada
Radio Frequency Range	Up to 250 feet
Software Configurable	Yes

Mechanical

Beep on Button Press	Yes, Software configurable
Beeper	Yes
Dimensions	4.1" H x 1.73" W x 1.6" D 104mm H x 44mm W x 40mm D
Depth into Electrical Box	1.3" 33mm
Enclosure Material	UV stabilized plastic
Mounting	Single or multi-gang junction boxes
Operating Environment	Indoors
Operating Humidity Range	0-90% relative humidity
Operating Temperature Range	32° to 104° F 0° to 40° C
Set Button	Yes
Storage Temperature Range	-4° to 158° F -20° to 70° C
Weight	4.5 oz 128 g

Electrical

Power Consumption	<0.4 Watts
Supply Voltage	120 Volts AC, 50/60 Hertz, single phase
Maximum Load	600W Incandescent 15A All Other Loads
Surge Resistance	Surges over 1000 volts
Power Connector	NEMA 5-15R
Certification	FCC ID Part 15B & 15C IC RSS-210 Issue 8 UL-498 Safety standard for receptacles CSA C22.2 #42 Including sections 131-135 for tamper-resistant outlets UL-244A, CAN/CSA C22.2#14 Standard for solid-state controls for appliances

Troubleshooting

The LED lights on the Wall Outlet are not illuminated

It is possible that your outlet is not getting power or that the status LEDs have been disabled.

Try this:

- Check to make sure power is flowing to your Insteon Wall Outlet. If your outlet was just installed, make sure the circuit breaker controlling the switch has been turned on. It is also advisable to verify the wire connections in the junction box are secure and not showing any bare wire.
- If the outlet works and the connected device can be controlled, use software or the Local Programming Flowchart to change the behavior of the status LED. The status LED brightness can be dimmed to the point that it appears off. The Insteon Hub and other central controller software allow setting of this device property.

Unable to add the Wall Outlet to a scene as a controller or a responder

If the device has power, something is likely interfering with the Insteon signal. Large appliances, power strips and some electronic devices may generate powerline noise.

Try this:

- Check to see if you have connected your Wall Outlet downstream of a GFCI outlet. GFCI outlets often unintentionally filter out the Insteon powerline signal. If testing the GFCI outlet disconnects power to your Wall Outlet, investigate alternative wiring options.
- Large appliances like refrigerators or air conditioners may be generating powerline noise that is disrupting the Insteon signal. If the issue only appears to happen when one of these large appliances is running, install a noise filter at that device. If you are uncertain of the device generating the noise, disconnect the potentially offending devices from power and test your Wall Outlet again. If the issue is resolved, install noise filters at each offending appliance.
- Some small electronics devices that include an AC/DC power supply can generate substantial electrical noise, in some cases, enough to disrupt an entire house of Insteon devices. Search your home for speaker docks, small stereos, etc. and disconnect them from power to perform testing. If removing these devices from your powerline resolves the Insteon issue, install a noise filter at each offending small electronic appliance.
- Your Wall Outlet may be too far from another Insteon device to receive a signal. Try locating a Range Extender or other Dual-Band Insteon device between the location of your Wall Outlet and the next nearest Insteon device.

The Wall Outlet is slow to respond to commands from a controller

This issue most likely lies with the controller, not the Wall Outlet; the controller is most likely repeating commands not acknowledged by an Insteon device that has been removed from the network. The repeated commands are slowing down the Insteon network, resulting in a delayed response from the Wall Outlet.

Try this:

- Consider if you have removed any Insteon devices from you network that were part of the slow-to-respond scene. If so, the links to these devices need to be removed from the controller. Use software to examine the database of the controller or if you know the modules that were removed, manually remove their links using the standard unlinking procedure.
- If you are unable to identify the missing devices, perform a factory reset on the controller. This will remove all links from the controller's database but will also require that you reconfigure the device's scenes and properties.

Troubleshooting

The connected light turned on by itself

There must be a device in your Insteon network that is unexpectedly linked to the Wall Outlet.

Try this:

- Use software to examine the Wall Outlet's links. If you can identify the stray controller, remove the link.
- If you are unable to identify the unexpected controller, perform a factory reset on the Wall Outlet. This will remove all links from the module's database but will also require that you reconfigure the device's scenes and properties.

Using a controller, the Wall Outlet will turn off but not turn on

Most likely, the Wall Outlet was linked to the controller with the load set to Off

Try this:

- Make sure the Wall Outlet's connected load is on and then re-link the device to your Insteon controller. This link will overwrite the previous "off" link.

The Wall Outlet does not respond to button taps or controller links

A power surge or excessive powerline noise may have caused the outlet to unexpectedly stop responding.

Try this:

- Temporarily disconnect your outlet from power by turning power off at the electrical service panel. Wait about 10 seconds and then restore power. Test the outlet to see if the load will turn on or off.
- While unusual, the Wall Outlet may require a factory reset to restore normal operation. Follow the procedure outlined in Local Programming to reset the device to factory settings. You will be required to reconfigure the device's scenes and properties after the reset.

After installing the Wall Outlet, the switch produces a long, continuous beep

Your Wall Outlet has been wired incorrectly and will not function.

Try this:

- Turn off power and verify the wire connections in the junction box are secure, not showing any bare wire and labeled correctly. The color of wire in your junction box may differ from the installation diagrams and it is possible that the function of the wire is incorrect for its color. Use a voltage detector or multi-meter to properly identify line and neutral. If you are unable to do so, contact an electrician.

Certifications and Warnings

This product is not designed or approved for use on powerlines other than 120VAC, 50Hz or 60Hz, single phase. Attempting to use this product on unapproved powerlines may have hazardous consequences.

- Use only indoors or in outdoor rated box
- This product may feel warm during operation. The amount of heat generated is within approved limits and poses no hazards. To minimize heat buildup, ensure the area surrounding this product is as clear of clutter as possible.
- Each Insteon product is assigned a unique Insteon I.D., which is printed on the product's label.
- To reduce the risk of overheating and possible damage to other equipment, do not use this product to control loads in excess of the specified maximum(s) or, install in locations with electricity specifications which are outside of the product's specifications. If this device supports dimming, please note that dimming an inductive load, such as a fan or transformer, could cause damage to the dimmer, the load bearing device, or both. If the manufacturer of the load device does not recommend dimming, use a non-dimming Insteon device. **USER ASSUMES ALL RISKS ASSOCIATED WITH DIMMING AN INDUCTIVE LOAD.**

The digital circuitry of this device has been tested and found to comply with the limits for a Class B digital device, pursuant to Part 15B of the FCC Rules. These limits are designed to provide reasonable protection against harmful interference in residential installations. This equipment generates, uses, and can radiate radio frequency energy and, if not installed and used in accordance with the instructions, may cause harmful interference to radio and television reception. However, there is no guarantee that interference will not occur in a particular installation. If this device does cause such interference, which can be verified by turning the device off and on, the user is encouraged to eliminate the interference by one or more of the following measures: • Re-orient or relocate the receiving antenna of the device experiencing the interference • Increase the distance between this device and the receiver • Connect the device to an AC outlet on a circuit different from the one that supplies power to the receiver • Consult the dealer or an experienced radio/TV technician.

WARNING: Changes or modifications to this device not expressly approved by the party responsible for compliance could void the user's authority to operate the equipment.

Cet appareil a été testé et s'avère conforme aux restrictions relatives aux équipements numériques de classe B, d'après l'article 15 des règlements du Conseil supérieur de l'audiovisuel américain (FCC). Ces restrictions ont été instaurées pour offrir une protection raisonnable contre les interférences nuisibles au sein d'une installation résidentielle. Cet appareil génère, utilise et peut émettre des fréquences radio et s'il n'est pas installé selon les instructions, peut nuire aux radiocommunications. Toutefois, rien ne garantit que des parasites ne surviendront pas dans une installation particulière. Si cet appareil cause des interférences nuisibles à la réception du téléviseur ou de la radio, ce que vous pouvez déterminer en ouvrant et en fermant votre appareil, nous vous invitons à essayer l'une des mesures correctives suivantes : • Réorientez l'antenne de réception installée sur l'appareil qui manifeste les parasites.

- Éloignez l'appareil du composant qui reçoit les ondes.
- Branchez l'appareil dans une prise de courant CA différente de celle du composant qui reçoit les ondes.
- Au besoin, consultez votre marchand électronique ou un technicien spécialisé dans le service des radios/téléviseurs pour des suggestions supplémentaires.

Product Warranty

Limited Warranty

Seller warrants to the original consumer purchaser of this product that, for a period of two years from the date of purchase, this product will be free from defects in material and workmanship and will perform in substantial conformity to the description of the product in this Owner's Manual. This warranty shall not apply to defects or errors caused by misuse or neglect. If the product is found to be defective in material or workmanship, or if the product does not perform as warranted above during the warranty period, Seller will either repair it, replace it, or refund the purchase price, at its option, upon receipt of the product at the address below, postage prepaid, with proof of the date of purchase and an explanation of the defect or error. The repair, replacement, or refund that is provided for above shall be the full extent of Seller's liability with respect to this product. For repair or replacement during the warranty period, call 866-243-8022 with the Model # and Revision # of the device to receive an RMA# and send the product, along with all other required materials to:

Insteon
ATTN: Receiving
16542 Millikan Ave.
Irvine, CA 92606-5027

Limitations

The above warranty is in lieu of and Seller disclaims all other warranties, whether oral or written, express or implied, including any warranty of merchantability or fitness for a particular purpose. Any implied warranty, including any warranty of merchantability or fitness for a particular purpose, which may not be disclaimed or supplanted as provided above shall be limited to the two-year of the express warranty above. No other representation or claim of any nature by any person shall be binding upon Seller or modify the terms of the above warranty and disclaimer.

Home automation devices have the risk of failure to operate, incorrect operation, or electrical or mechanical tampering. For optimal use, manually verify the device state. Any home automation device should be viewed as a convenience, but not as a sole method for controlling your home.

In no event shall Seller be liable for special, incidental, consequential, or other damages resulting from possession or use of this device, including without limitation damage to property and, to the extent permitted by law, personal injury, even if Seller knew or should have known of the possibility of such damages. Some states do not allow limitations on how long an implied warranty lasts and/or the exclusion or limitation of damages, in which case the above limitations and/or exclusions may not apply to you. You may also have other legal rights that may vary from state to state.