



5800PIR Series

Wireless Motion Detectors

The Honeywell Home 5800PIR Series of Wireless Motion Detectors are high-performance, easy-to-install sensors featuring sleek, compact designs that are ideal for applications where aesthetics or discretion are critical. On the 5800PIR and 5800PIR-COM, PIR sensitivity and temperature sensing can be enabled via programming locally or from the central station. Installation is easy, with no jumpers, switches or disassembly, fewer mounting restrictions and an automatic walk test mode that turns on the walk test LED for ten minutes—saving installers one trip up the ladder for each sensor. Other notable benefits include fewer service calls thanks to a long-life battery and empty cases which allow designers and end-users to custom-paint the motion detectors to match any residential or commercial setting. The 5800PIR blends perfectly with all of the 5800 Series family of sensors for a seamless look.



Resideo Total Connect Ready!

FEATURES AND BENEFITS

• **Faster and Easier to Install**

Specific features that contribute to this benefit include:

- Automatic walk test
- Flashlight walk test
- No DIP switches/jumpers
- Remotely programmable sensitivity
- No mounting height adjustments
- Circuit board does not need to be removed to install on wall
- Ceiling and wall mounting brackets help to easily direct the pattern where needed
- 7'-9' mounting height means fewer restrictions than current offerings (6.5'-7.5')
- Easy opening case
- Covered circuit board reduces risk of installer initiated damage

• **Fewer Service Calls**

Incorrect installation of equipment or changing requirements of the site (new pets) is no longer a problem

- Automatic walk test mode turns on the walk test LED for ten minutes when cover is opened and closed or when a battery is installed. Walk test mode can also be triggered with a flashlight on the 5800PIR and 5800PIR-COM.
- Remotely programmable
- Longer battery life
- End-user replaceable batteries
- Black bug guard means 15% fewer false alarms due to bright lights directed into the PIR
- UV protected lenses (on all models except 5800PIR-RES)

• **Smaller/Better with a Family Look**

The new PIRs are 50% smaller than the 5890PI. Also, dealers can install one family look whether they use hardwired, V-Plex or wireless in order to complete the job. In addition, if the dealers need to mix and match sensing technologies, the look of the installation is consistent.

• **Less Costly Maintenance**

Only one battery to replace.

• **Decreased Liability**

Self test—alerts end-user and central station if the motion detector stops functioning (except 5800PIR-RES)

• **Optional Cold Temperature Alert**

(< 45° F) warns when temperatures are approaching the freezing point (except 5800PIR-RES).

• **Commercial Dealer—Additional Benefits**

- New longer range patterns allow more wireless options
- Colder operation down to -20° C (-4° F) for use in unheated areas
- Look down option provides increased security right below the detector
- Back tamper switch—required for commercial certificated installations

5800PIR Series Technical Specifications

	5800PIR-RES	5800PIR	5800PIR-COM
Pet Immunity	Yes, always 80 lbs.	Yes (0 or 80 lbs.)	No
Self Test	No	Yes	Yes
Look Down Zone	No	Yes, selectable	Yes, selectable
Remotely Programmable Pet Immunity and Low Temp Sensing	No	Yes	Yes
Cold Temperature Alert	No	Yes	Yes
UV protected Lens	No	Yes	Yes
Walk Test Enabled with Flashlight	No	Yes	Yes
Screws, Wall Mounts and Lens Mask Provided	No	Yes	Yes
Front and Rear Cover Tamper	No	Yes	Yes
Agency Listings	cETLus	UL	UL
Battery Pull Tab	No	Yes	Yes
Temperature Range	14° F to 131° F (-10° C to 55° C)	14° F to 131° F (-10° C to 55° C)	-4° F to 131° F (-20° C to 55° C)
Patterns/Range	35' x 40'	35' x 40'	60' x 80' or 100' x 20'

DETECTION PATTERNS

5800PIR/5800PIR-RES Top View

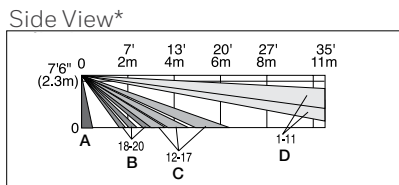
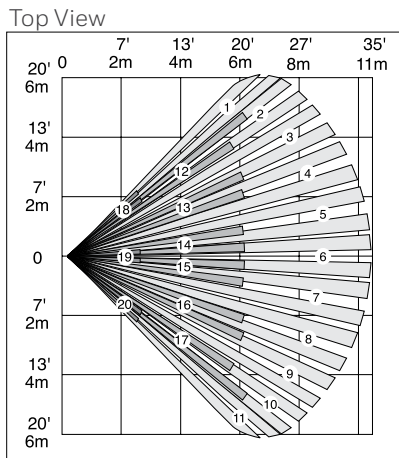

5800PIR-COM Top View

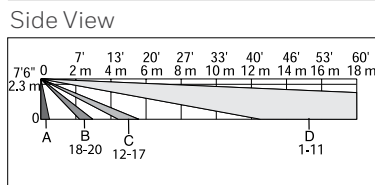
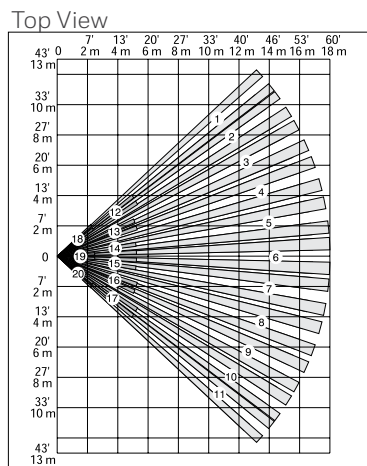

5800PIR-COM

(additional curtain lens included:
5800PIR-COM only)

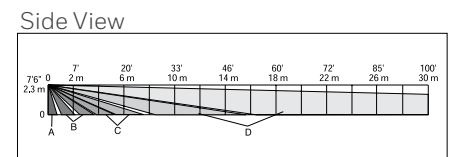
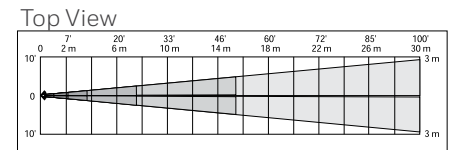

Legend

A	Look Down
B	Lower
C	Intermediate
D	Long

*Look Down is not available on the 5800PIR-RES.

5800PIR Series Technical Specifications

Detection Method: Dual Element
Passive Infrared

Range:

5800PIR-RES = 35' x 40' (11m x 12m)
5800PIR-COM = 60' x 80' (18m x 26m);
100' x 20' (30m x 6m)

Power: Battery (included) – 1 x 3V,
CR123A/DL 123A /466

Battery Life*: Up to seven years; 38%
longer battery life than 5890PI (in a
typical installation with an average of 80
motion events per day)

RF Frequency: 345 MHz

Operating Temperature:

(for indoor use environment)
14° F to 131° F (-10° C to 55° C)

(for indoor use environment)
-4° F to 131° F (-20° C to 55° C)
for the 5800PIR-COM

Relative Humidity, non-condensing:
95% max

Detectable Walk Rate:
0.7 – 7ft/Sec. (0.2 – 2.0m/Sec.)

Temperature Compensation:
Advanced Dual Slope

Pet/Animal Immunity: (5800PIR and
5800PIR-RES only)—up to 80 lbs. (36Kg)

Mounting Height: 7' to 9' (2.3m to 2.7m)

Tamper Switch: Front and cover/back

Sensitivity:

Remotely selectable—5800PIR—high,
pulse count 1 (no pet immunity) or
low, pulse count 2 (up to 80 lbs. of Pet
Immunity)

5800PIR-COM—high, pulse count 1
or low, pulse count 2

Self Test (5800PIR and 5800PIR-COM):

Internally checks the PIR circuit every 10
minutes and disables the RF supervision
signal if six consecutive self tests fail

PIR Fields of View:

35' Pet Immune Lens = 102 zones
(44 long range, 36 intermediate,
18 lower, four look-down)

60' x 80' lens = 66 zones (44 long
range, 12 intermediate, six lower, four
look-down)

100' x 20' lens = 16 zones (four long
range, four intermediate, four lower,
four look-down)

Low Temperature Detection:

Fault = < 45° F (7° C) for > 10 to 30
minutes

Restore = > 48° F (9° C) for > 10 to 30
minutes

Dimensions:

W= 8.7cm [2.4"]

H= 6.1cm [3.4"]

D= 3.9cm [1.5"]

Weight: 81G, [2.9oz] Packaged product =
112G, [4oz]

Includes:

Mounting hardware (5800PIR and
5800PIR-COM only)
Lens Masking (5800PIR and 5800PIR-
COM only)
Look Down Lens (5800PIR and
5800PIR-COM only)
3V Lithium Battery
100' x 20' Curtain Lens (5800PIR-
COM only)

Approvals/Listings:

FCC part 15, Class B verified
IC, ICES-003, Class B verified
C-Tick
CE
SIA-PIR-01 Passive Infrared detector
standard features for false alarm
immunity
cETLus
UL

*Battery life may vary depending on alarms per day and environmental conditions of the installation site.

5800PIR Series Technical Specifications

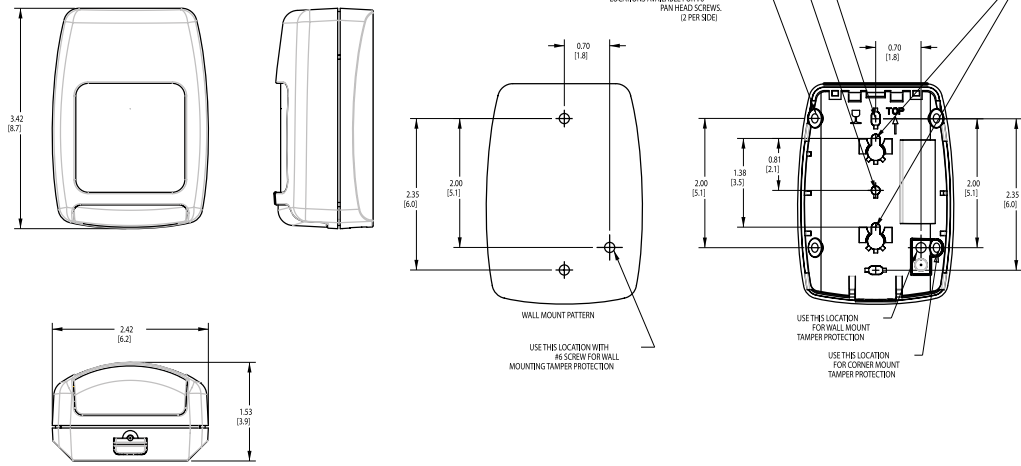

5800PIR WIRELESS MOTION SENSOR

DIMENSIONS: INCHES (CENTIMETERS)

ORDERING

5800PIR-RES	Entry Level Wireless PIR Motion Sensor, 80 lbs., 35' x 40' Range
5800PIR	Fully Featured Wireless PIR Motion Sensor, 0 or 80 lbs., 35' x 40' Range
5800PIR-COM	Long Range Wireless PIR Motion Sensor 60' x 80' or 100' x 20' Range

ACCESSORIES

0-000-110-01	SMB10 Universal White Swivel Mount Bracket (5 pack)
0-000-155-01	SMB10T Tampered Universal White Swivel Mount Bracket (5 pack)
0-000-111-01	SMB10C Universal White Ceiling Mount Bracket (5 pack)
IS2500-HSLK	35' High Security Lens Kit (10 pack)
IS2500-PALK	Pet Alley Lens Kit (10 pack)
5800PIRCASE-WH	White Empty Case for 5800PIR Family



For more information
security.honeywellhome.com/hsc



Resideo Technologies, Inc.
 2 Corporate Center Drive, Suite 100
 P.O. Box 9040
 Melville, NY 11747
 1-800-645-7492
resideo.com

L/5800PIRD/D | 05/19
 © 2019 Resideo Technologies, Inc.
 This product is manufactured
 by Resideo and its affiliates. The
 Honeywell Home trademark is
 used under license from Honeywell
 International Inc. All rights reserved.

