

FEATURES & SPECIFICATIONS

INTENDED USE — Ideal for applications requiring low-profile, attractive emergency lighting with Optional normally-off or normally-on with photocell control. Provides a minimum of 90 minutes of illumination both indoors and outdoors upon loss of AC power. **Certain airborne contaminants can diminish the integrity of acrylic and/or polycarbonate.** [Click here for Acrylic-Polycarbonate Compatibility table for suitable uses.](#)

CONSTRUCTION — Compact, low-profile, architectural design with die-cast aluminum housing. Finishes are texturized powder coat paint for dark bronze, white, black and non-texturized for natural aluminum. Test switch indicator light and remote enabled are located on the bottom of the housing and are easily accessible and visible from the floor.

OPTICS — LEDs with L70 of 55,000 hours. Delivers 635 lumens in Normal-On and Emergency operation. Optional field configurable for wide and forward throw distribution (**U.S. Patent No. - US10236712 B2**).

Outdoor wide throw distribution: 70' (3' path of egress) at a 7.5' mounting height with 1 FC Average. 4,000K correlated color temperature (CCT).

70 CRI.

ELECTRICAL — UVOLT (120 thru 347V, 50/60hz). Current-limiting charger maximizes battery life and minimizes energy consumption to provide low operating costs. Small battery chargers Certified in the CA Title 20 Appliance Efficiency Database

Short-circuit protection — current-limiting charger circuitry protects printed circuit board from shorts. Regulated charge voltage maintains a stable charge voltage over a wide range of line voltages.

Prevents over/undercharging that shortens battery life and reduces capacity. Filtered charger input minimizes charge voltage ripple and extends battery life.

Photocell option (PEL) for normally on product in order to discontinue illumination during periods when ambient light is present. Photocell option (PEL) for normally on products allow the user to force lamp illumination by user control (external switch). When power is not connected to switched line, illumination will respond to internal daylight sensor. For switched line applications, no other types of products shall be connected on the switched leg.

Remote units (OELR) are normally off. Emergency only functionality with DC power from an external battery.

BATTERY: Sealed, maintenance-free Lithium Iron Phosphate battery.

SELF-DIAGNOSTICS AND REMOTE TEST (SDRT OPTION): Automatic 24-hour recharge after a 90-minute discharge. Advanced electrical design provides constant light output throughout the entire discharge period for non-CW batteries. (For cold weather and cold temperature applications, the light may diminish though the discharge cycle). Brownout protection is automatically switched to emergency mode when supply voltage drops below approximately 80 percent nominal of 120, 220, 277 or 347. Other input voltages may vary. AC/LVD re-set allows battery connection before AC power is applied and prevents battery damage from deep discharge.

Self-Diagnostics: Continuously monitors AC functionality. Standard derangement monitoring will indicate disconnected battery, charger failure and displays green flashing indicator light while in emergency mode. Single multi-chromatic LED indicator to display two-state charging, test activation and three-state self-diagnostics.

Self-diagnostic testing: Five minutes every 30 days and 90 minutes annually. Diagnostic evaluation of lamps, AC to DC transfer, battery charging and condition of microprocessor. Automatic test is easily postponed for eight hours by activating manual test switch or use of remote tester (RTKIT accessory).

Manual testing: Test switch and remote tester (RTKIT accessory) provides manual activation of 60-second diagnostic testing for on-demand visual inspection. 90 minute manual testing can be enabled by pressing the test switch again while in test mode.

INSTALLATION — Wall mount: typically meets 7.5' to 14' mounting height from ground or floor. Power supplied by either mounting directly to a 4" square or 4" octagon j-box (wall mount) and accepts rigid or flex conduit.

LISTINGS — UL wet location listed standard at 32-122°F (0-50°C). Unit with CW battery(cold weather) listed for -22°F to 122°F (-30° to 50°C). Remote listed for -40°F to 122°F (-40° to 50°C). Meets or exceeds all applicable requirements for UL 924, NFPA 101 (current Life Safety code), NFPA 70 (NEC), NOM (Norma Oficial Mexicana), California Energy Commission Title 20 section 1605.3 (W)(4), FCC Title 47, Part 15, Subpart B and OSHA. List and labeled to comply with Canadian Standards C22.2 No. 141-10. Meets City of Chicago Code.

Government Procurement:

BAA - Buy America(n) Act: Product with the BAA option qualifies as a domestic end product under the Buy American Act as implemented in the FAR and DFARS. Product with the BAA option also qualifies as manufactured in the United States under DOT Buy America regulations.

BABA - Build America Buy America: Product with a BAA option also qualifies as produced in the United States under the definitions of the Build America, Buy America.

Please refer to www.acuitybrands.com/buy-american for additional information.

WARRANTY — 5-year limited warranty (Battery is prorated). This is the only warranty provided and no other statements in this specification sheet create any warranty of any kind. All other express and implied warranties are disclaimed. Complete warranty terms located at: www.acuitybrands.com/support/warranty/terms-and-conditions

Note: Actual performance may differ as a result of end-user environment and application. All values are design or typical values, measured under laboratory conditions at 25 °C. Specifications subject to change without notice.

† Small Battery Chargers Certified in the CA Title 20 Appliance Efficiency Database.

Catalog Number
Notes
Type

Premium Die-Cast Architectural Emergency Light

AFF



without photocell (white)



without photocell (natural aluminum)



with photocell (white)



with photocell (dark bronze)

MOUNTING

All dimensions are inches (centimeters).

Shipping weight: 3.5 lbs. (1.59 kgs.)

Length: 6 1/2 (16.51)

Depth: 3 27/100 (8.30)

Height: 10 (25.45)

Weight : 3.5 lbs (1.59kg)

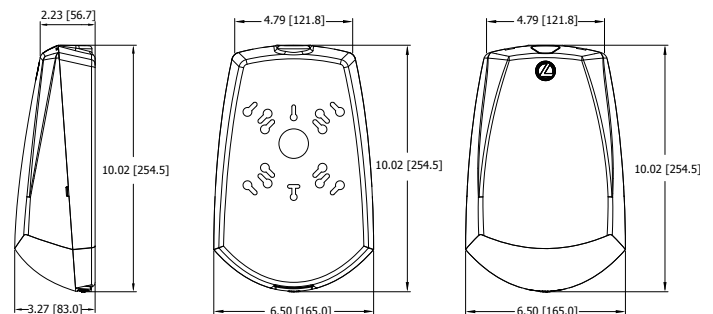

AFF Signature® Premium Die-Cast Architectural Emergency Light

SELF-POWERED MODELS

ORDERING INFORMATION

For the shortest lead times, configure product using **bolded options**.

Example: AFF PEL DWHGXD UVOLT LTP SDRT WT

Series	Unit Type ¹	Housing Color	Voltage	Battery Type	Automatic Testing	Optics	Options
AFF Signature® Premium	PEL Photocell; Normally-ON with internal battery OEL Normally-OFF with internal battery	DWHGXD White textured DBLBXD Black textured DNAXD Natural aluminum DDBTXD Dark bronze textured	UVOLT 120-347VAC, 50/60Hz	LTP Lithium Iron Phosphate	SDRT Self-diagnostics remote test	WT Wide Throw FCT Field configurable throw ²	CW Cold Weather (-30 - 50C) BAA Buy America(n) Act and/or Build America Buy America Qualified

Notes

- AFF with internal battery is not remote capable.
- FCT optics ships standard in the WT (wide throw) mode. Upon installation, configuration can be changed to the FCT mode.

REMOTE MODELS listed for -40°F to 122°F (-40° to 50°C)

ORDERING INFORMATION

For the shortest lead times, configure product using **bolded options**.

Example: AFF OELR DWHGXD WT

Series	Unit Type	Housing Color	Voltage	Optics	Options
AFF Signature® Premium	OELR Remote fixture, Normally OFF (requires external battery source)	DWHGXD White textured DBLBXD Black textured DNAXD Natural aluminum DDBTXD Dark bronze textured	(blank) Universal DC voltage (8-30VDC)	WT Wide Throw	BAA Buy America(n) Act and/or Build America Buy America Qualified

Accessories: Order as separate catalog number.

RTKIT Remote test kit, up to 40' away (includes goggles, laser and battery)

AFF SPACING GUIDELINES

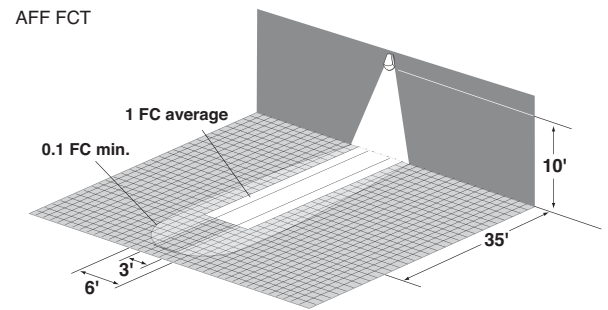
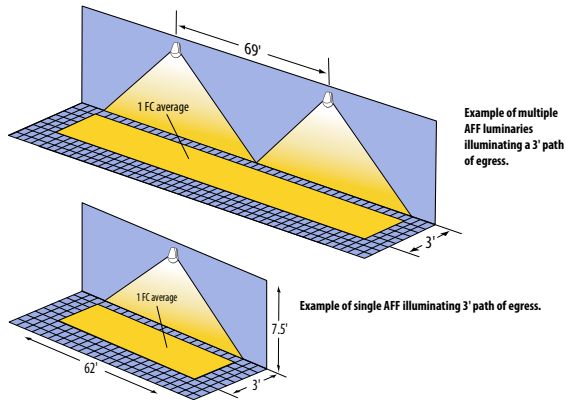

Maximum Spacing Guidelines - AFF (WT)

Mounting Height	Illumination Level	Single Luminaire		Multiple Luminaire		Application Notes *
		3' Path of Egress	6' Path of Egress	3' Path of Egress	6' Path of Egress	
7.5'	1FC Avg	62'	46'	69'	53'	200' Open Space 80/50/20 reflectances
10'		48'	34'	55'	46'	
12'		28'	22'	46'	41'	
14'		6'	N/A	38'	36'	

* Also meets the additional illumination requirements of NFPA 101: 1FC minimum and max/min ratio of 40:1.

Maximum Spacing Guidelines - AFF (FCT)

Mounting Height	Illumination Level	Single Luminaire		Application Notes *
		3' Path of Egress	6' Path of Egress	
7.5'	1FC Avg	24'	23'	200' Open Space 80/50/20 reflectances
10'		35'	35'	
12'		37'	31'	
14'		31'	N/A	

* Also meets the additional illumination requirements of NFPA 101: 1FC minimum and max/min ratio of 40:1.

SPECIFICATIONS

Electrical: Primary Circuit

Unit Type	Battery Type	Input Voltage(V)	Input Current(A)	Watts(W)
PEL WT	LTP	120-347	0.053-0.086	11.28
	LTP CW	120-347	0.089-0.167	20.39
PEL FCT	LTP	120-347	0.053-0.086	11.28
	LTP CW	120-347	0.089-0.167	20.39
OEL WT	LTP	120-347	0.025-0.032	2.50
	LTP CW	120-347	0.075-0.097	11.60
OEL FCT	LTP	120-347	0.025-0.032	2.50
	LTP CW	120-347	0.075-0.097	11.60
OELR WT	N/A	8-30	0.248 - 1.225	8.57*

*OELR watts data is in addition to the lamp heads on the product

BATTERY

Lithium Iron Phosphate					
Type	Voltage	Typical Shelf Life ¹	Typical Life ¹	Maintenance ²	Temperature range ^{3,4}
STD	12.8V	1 year	6-8 years	none	32 - 122°F (0 - 50°C)
CW	12.8V	1 year	6-8 years	none	-22 - 122°F (-30 - 50°C)

Notes

- 1 At 77°F (25°C).
- 2 Battery life is negatively impacted by many variables including temperature, charging rates, number of cycles and deep discharges due to long periods of time without AC power.
- 3 All life safety equipment, including emergency lighting for path of egress must be maintained, serviced, and tested in accordance with all National Fire Protection Association (NFPA) and local codes. Failure to perform the required maintenance, service, or testing could jeopardize the safety of occupants and will void all warranties.
- 4 Temperature range where unit will provide capacity for 90 minutes. Higher and lower temperatures affect life and capacity. See option packages for expanded temperature ranges.