

# Installation Instructions

## Dimensions 4000 series architectural controller

Applies to models: D4104, D4106, D4200, D4206, & D4006

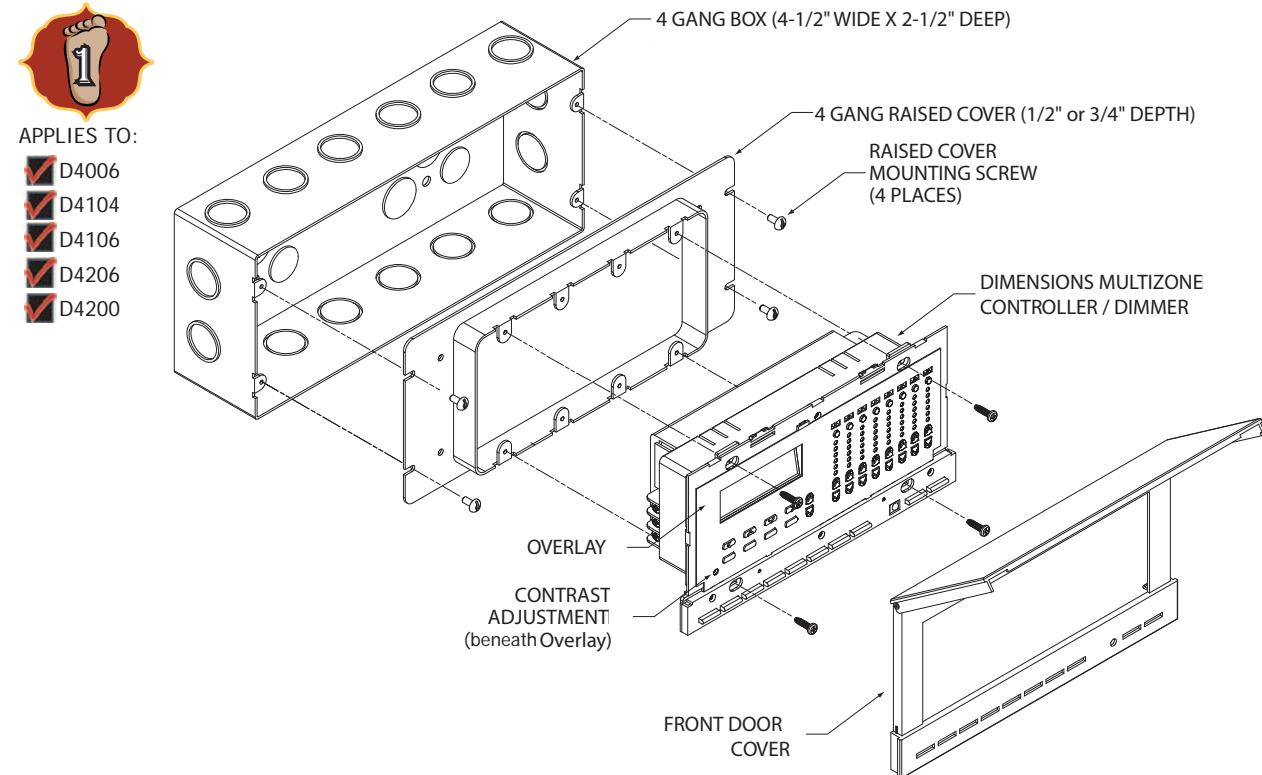

Exploded Installation View

### Items required for installation

- Suitable Backbox
  - Preferred 4 gang 'Gang Box', Raco #943
  - Leviton P/N BBG04-000
  - 5 gang device backbox
- Appropriate backbox device plate
  - Raised cover for 4 gang gang box
  - Leviton P/N WPG04-00R
  - 4 gang reducer "mud ring" for 5 gang device backbox

D4006, D4104, D4106, D4206	D4200
<ul style="list-style-type: none"> <li>Input power (see specs)</li> <li>Output to loads</li> <li>Optional Luma-Net network connection</li> </ul>	<ul style="list-style-type: none"> <li>Luma-Net network connection</li> </ul>

### General Installation Steps

- Read all installation instructions and plan entire system
- Determine location for device and install the appropriate backbox

D4006, D4104, D4106, D4206	D4200
<ol style="list-style-type: none"> <li>Connect input power.</li> <li>Connect power to loads.</li> <li>Make connections to network (if applicable.)</li> <li>Inspect wiring.</li> <li>Install device in wall.</li> <li>Power up and test system.</li> <li>Configure.</li> </ol>	<ol style="list-style-type: none"> <li>Make network connections.</li> <li>Inspect wiring.</li> <li>Install device in wall.</li> <li>Power up &amp; test system.</li> <li>Configure.</li> </ol>

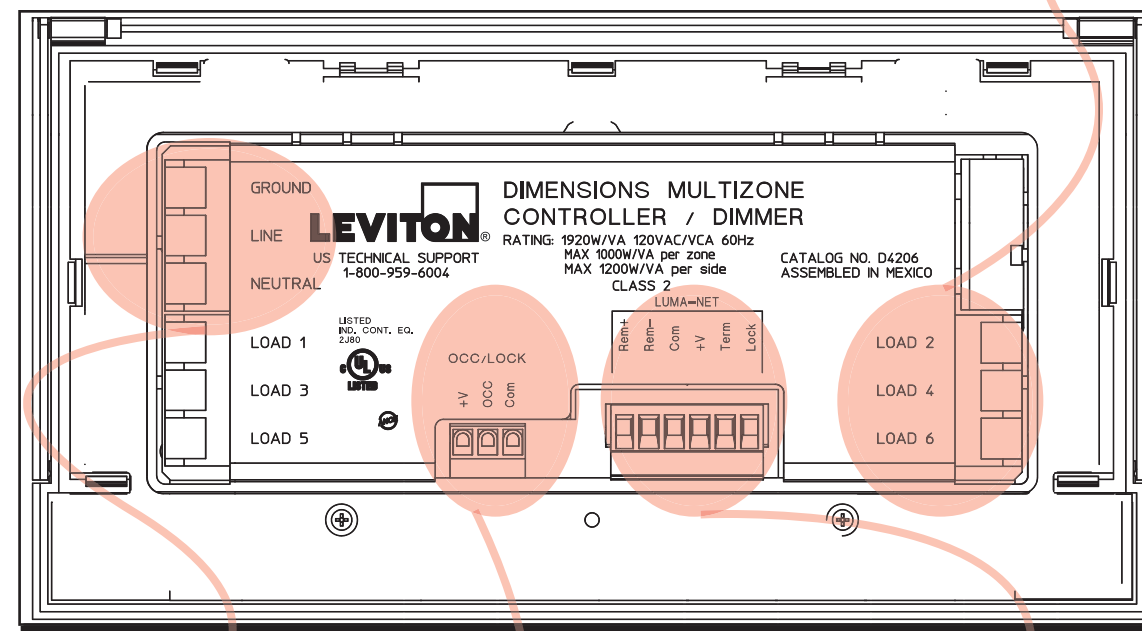

**APPLIES TO:**

- D4006
- D4104
- D4106
- D4206
- N/A D4200

### Line Voltage Load Termination

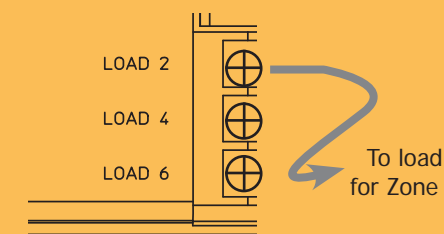

- Notes:**
- Use Copper Wire only.
  - Max (2) #12AWG per terminal.
  - Torque terminals to 9in-lbs.
  - 75° min insulation temperature rating.
  - Remove 3/8" insulation from each circuit conductor.
  - The number of outputs on a specific model may differ from that shown.

- Install Steps:**
- Confirm that the load (watts) is within the specifications for your model as shown in the specification chart.
  - Confirm that the load type is supported. Load types can be found in the specification chart.
  - Identify the terminal to which you need to connect the load, strip the wire as appropriate, and install to the appropriate load terminal.



**APPLIES TO:**

- D4006
- D4104
- D4106
- D4206
- D4200

### Luma-Net Network

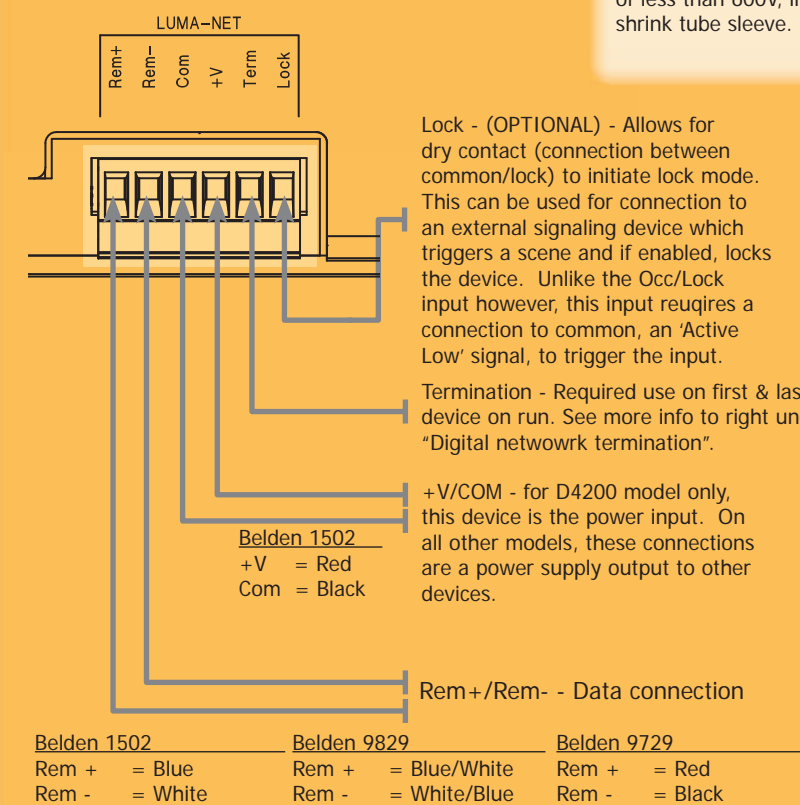

**Background:** The Luma-Net network is used for entry stations, partition control/room combine stations, dimmer cabinets, relay cabinets, and other devices which may be required.

- Installation Steps:**
- Connect all wires as shown. Observe all notes, instructions, and low voltage digital network data cable installation best practices.
  - Use Belden #1502R or #1502P for inter-connection of devices. Belden #9829, #9729, & #88102 are also supported wire types, however, an additional pair of (2) #18AWG wires is required.
  - A maximum run length of 2000 feet is supported on the data pair.
  - Torque terminals to 7in-lbs.
  - 75° min insulation temperature rating.
  - Remove 3/8" insulation from each circuit conductor.
  - Only 1 power supply is allowed on any network segment. If other power supplies are already supplying power to the network segment, do not connect +V between sources. Consult factory if unsure as to the proper power routing or connections for the network.
  - Terminals support 30-12AWG stranded wire.

- Notes:**
- Luma-Net networks require a daisy chain topology
  - Use Belden #1502R or #1502P for inter-connection of devices. Belden #9829, #9729, & #88102 are also supported wire types, however, an additional pair of (2) #18AWG wires is required.
  - A maximum run length of 2000 feet is supported on the data pair.
  - Torque terminals to 7in-lbs.
  - 75° min insulation temperature rating.
  - Remove 3/8" insulation from each circuit conductor.
  - Only 1 power supply is allowed on any network segment. If other power supplies are already supplying power to the network segment, do not connect +V between sources. Consult factory if unsure as to the proper power routing or connections for the network.
  - Terminals support 30-12AWG stranded wire.

### SPECIFICATIONS

Power Input (D4200 N/A)	120VAC 60hz, 10% tolerance	230VAC 50/60hz, 10% tolerance
Power Output (D4200 N/A)	<ul style="list-style-type: none"> <li>1000 Watts max per zone, minimum load 15W per zone</li> <li>1200 Watts max per side</li> <li>1920 Watts max per device</li> </ul>	<ul style="list-style-type: none"> <li>800 Watts max per zone, minimum load 15W per zone</li> <li>1200 Watts max per side</li> <li>2400 Watts max per device</li> </ul>
Supported load Types (D4200 N/A)	<ul style="list-style-type: none"> <li>Incandescent</li> <li>Tungsten</li> <li>Magnetic Low Voltage</li> <li>2-Wire Fluorescent (Advance Mark 10, Lutron Tu-Wire)</li> <li>Electronic Low Voltage when rated for use with forward phase dimmers</li> <li>Neon / Cold Cathode</li> <li>Non-dim loads</li> </ul>	
Listings & Certifications	<ul style="list-style-type: none"> <li>UL/cUL</li> <li>California Title 24</li> <li>FCC Part 15, Class A</li> </ul>	Not for use in North America
Environmental	0°-40°C ≤ 90% non-condensing humidity	
Clock	Accuracy to +/- 15 seconds per week Astro Clock accurate to with 15 minutes	
Memory	Lifetime memory of configuration and recorded memories. Clock maintained for up to 10 days in the event of power failures	

**Daisy Chain Topology:** Daisy-chain topology is required for each Luma-Net segment. Star or other similar topologies are not allowed. If multiple home-runs are required, this topology can be supported when a Luma-Net Hub, P/N LHUB8-000, is used.

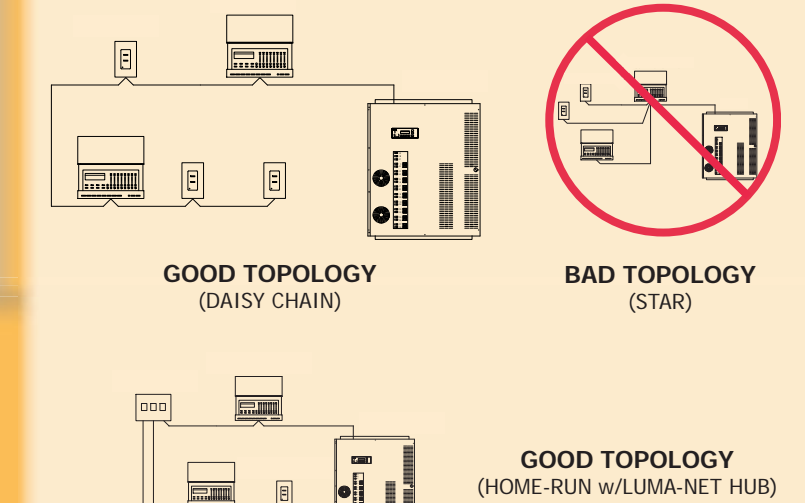

**Digital network termination:** The Luma-Net network requires that both ends of the network be terminated:

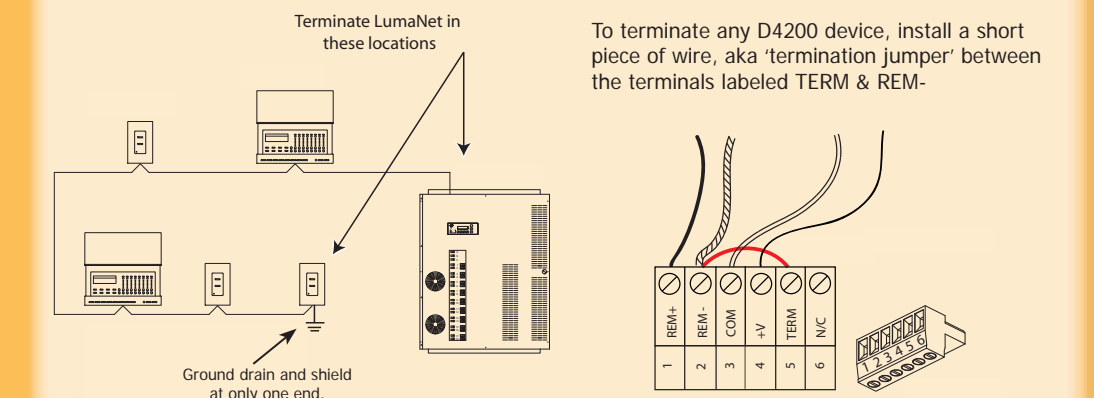

**Power Calculation:** When using the D4006, D4104, D4206, or D4200 as a supply to the Luma-Net network, ensure that there is enough supply current.

AVAILABLE SUPPLY CURRENT:  
**+24Vdc, 300ma (12 Unit loads)**

D4200 single gang devices each require 1 Unit Load  
D4200 LCD stations each require 2 Unit Loads  
Luma-Net hubs require 3 Unit Loads

When using **Belden 1502R (or 1502P)** the following maximum run lengths apply:

Unit Loads	Max run length (ft)
10	3,528
20	1,764
30	1,176
40	882

For applications which do not fit these conditions please contact the factory for assistance.



**APPLIES TO:**

- D4006
- D4104
- D4106
- D4206
- N/A D4200

### Power Input

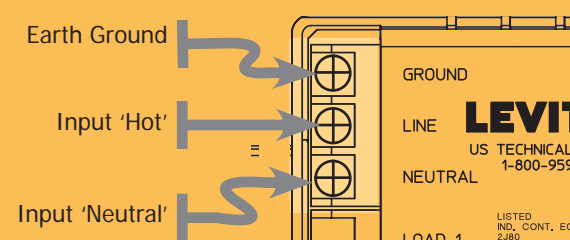

- Installation Steps:**
- Connection to dedicated input power circuit recommended.
  - Confirm input circuit has enough available power for controller plus all connected loads.
  - Connect line, neutral, and ground to terminals as indicated.

- Notes:**
- Use Copper Wire only
  - Max (2) #12AWG per terminal
  - Tighten terminals to 9in-lbs torque
  - 75° min insulation temperature rating
  - Remove 3/8" insulation from each circuit conductor



**APPLIES TO:**

- N/A D4006
- D4104
- D4106
- D4206
- D4200

### Auxiliary Input

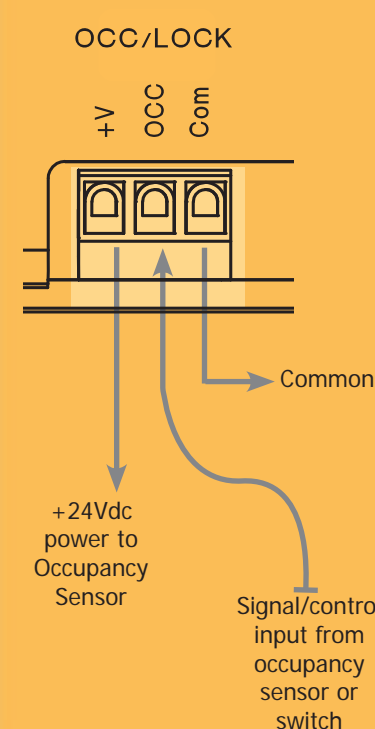

**Background:** Some models allow an external input which can trigger scene and/or device lockout. This can be used when it is desired to lockout a device by keyswitch, preventing access from the front panel, or when an Occupancy Sensor is used to turn on the lights.

- Installation Steps:**
- Connect +V/COM terminals to the power input of the signal device.
  - Output from the signalling device shall be connected to the OCC terminal.

- Notes:**
- When using low voltage wire with a rating of less than 600V, insulate with the included shrink tube sleeve.
  - OCC terminal requires +V to signal lock/occ mode.
  - Available power for all peripherals can not exceed 300mh.
  - Use Copper Wire only
  - Terminals accept #30-12AWG
  - Tighten terminals to 7in-lbs torque
  - 75° min insulation temperature rating
  - Remove 3/8" insulation from each conductor.

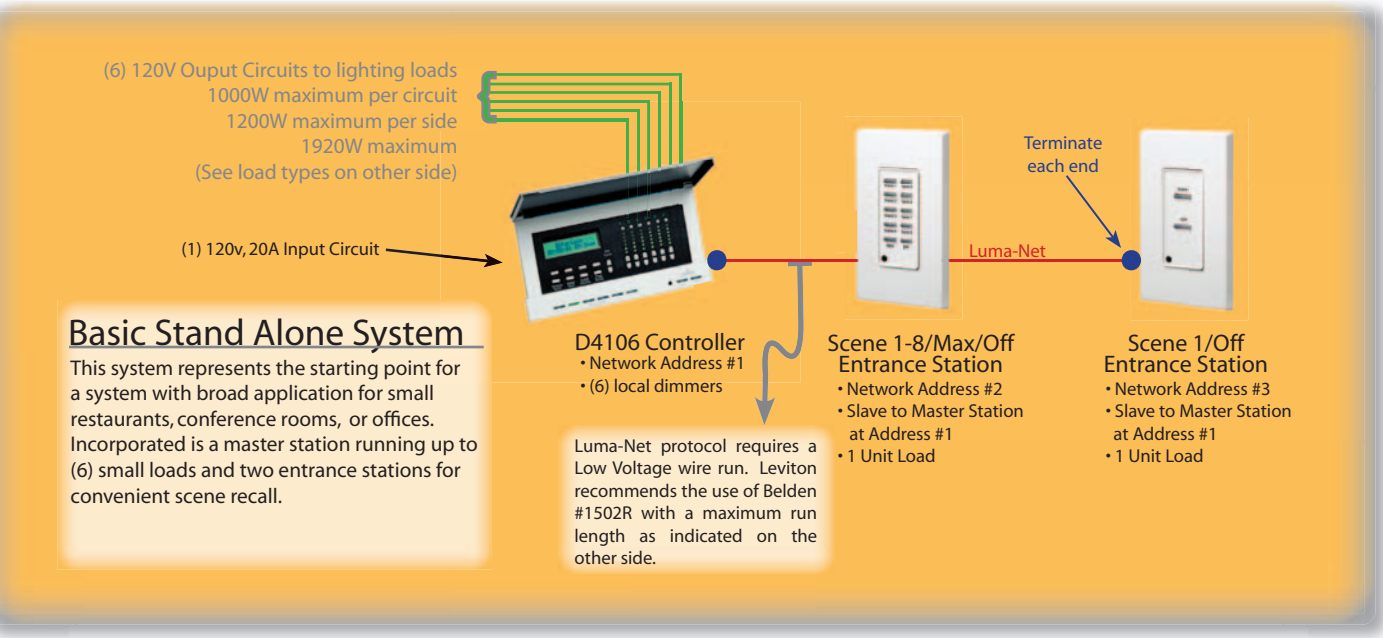

**Basic Stand Alone System**

This system represents the starting point for a system with broad application for small restaurants, conference rooms, or offices. Incorporated is a master station running up to (6) small loads and two entrance stations for convenient scene recall.

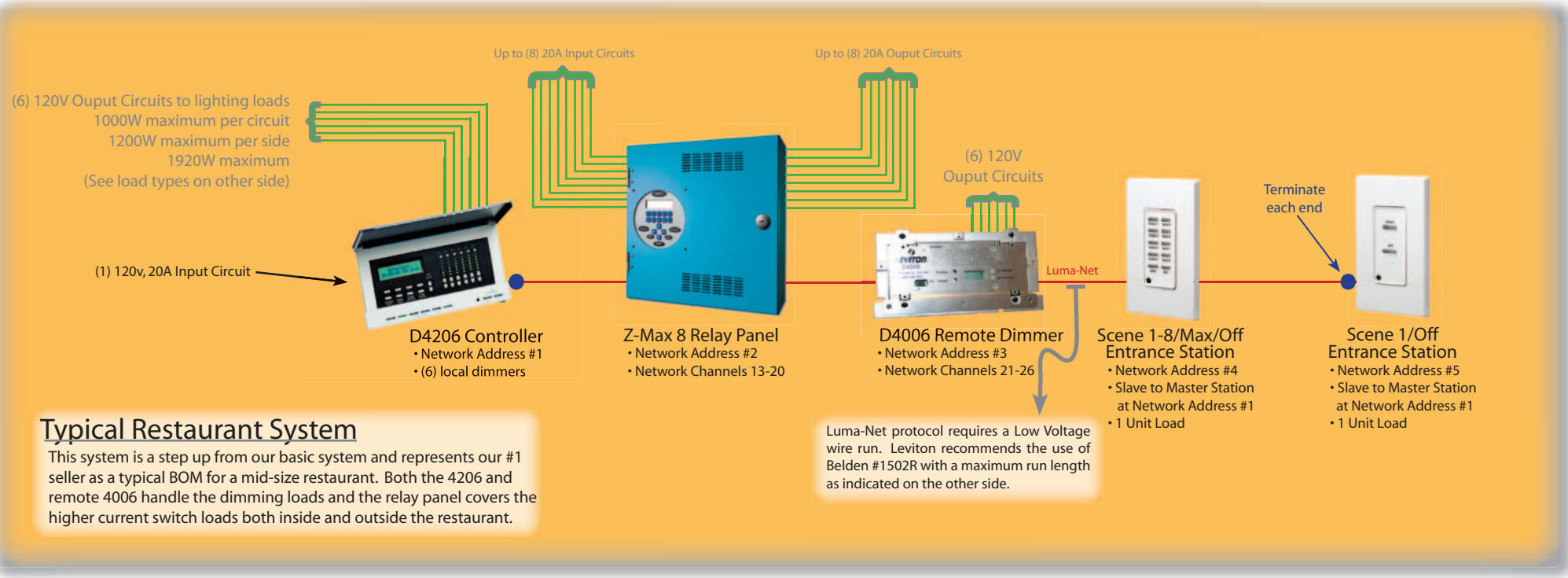

**Typical Restaurant System**

This system is a step up from our basic system and represents our #1 seller as a typical BOM for a mid-size restaurant. Both the 4206 and remote 4006 handle the dimming loads and the relay panel covers the higher current switch loads both inside and outside the restaurant.

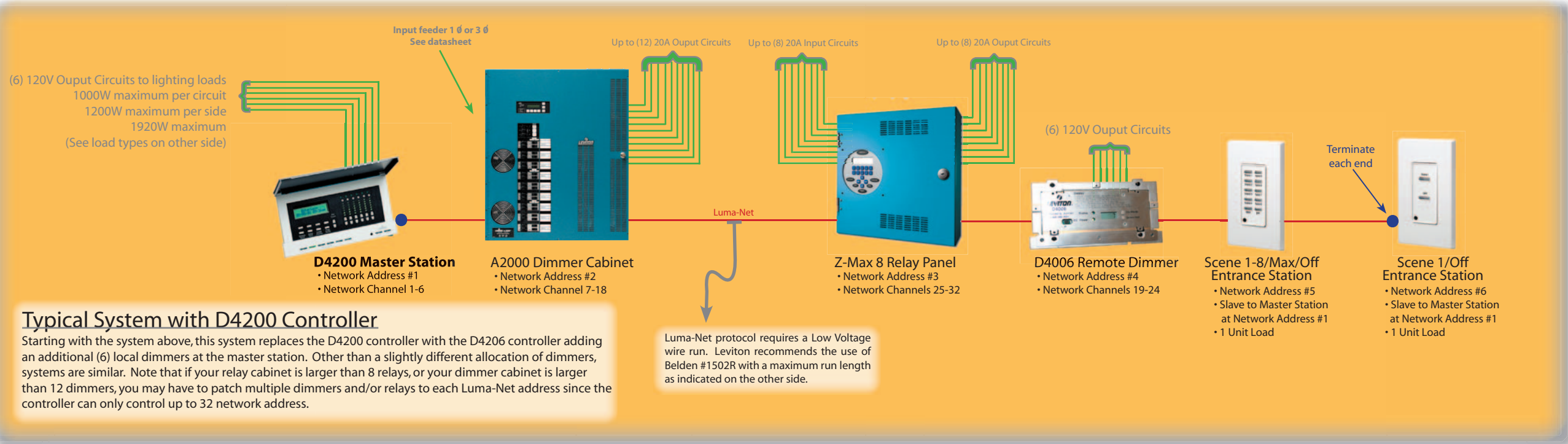

**Typical System with D4200 Controller**

Starting with the system above, this system replaces the D4200 controller with the D4206 controller adding an additional (6) local dimmers at the master station. Other than a slightly different allocation of dimmers, systems are similar. Note that if your relay cabinet is larger than 8 relays, or your dimmer cabinet is larger than 12 dimmers, you may have to patch multiple dimmers and/or relays to each Luma-Net address since the controller can only control up to 32 network addresses.

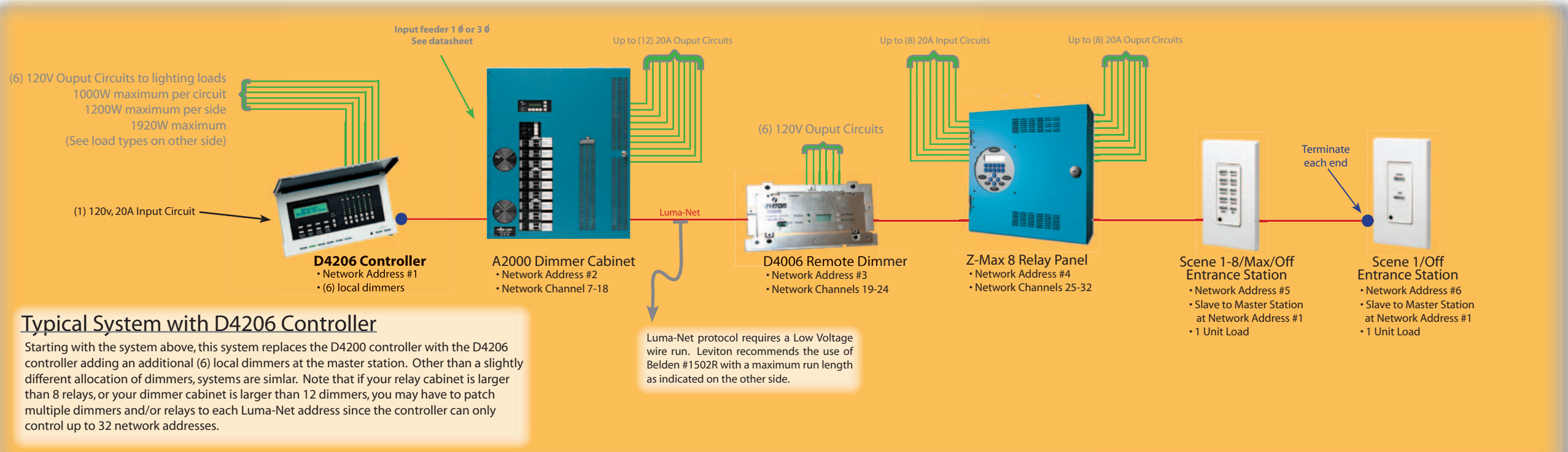

**Typical System with D4206 Controller**

Starting with the system above, this system replaces the D4200 controller with the D4206 controller adding an additional (6) local dimmers at the master station. Other than a slightly different allocation of dimmers, systems are similar. Note that if your relay cabinet is larger than 8 relays, or your dimmer cabinet is larger than 12 dimmers, you may have to patch multiple dimmers and/or relays to each Luma-Net address since the controller can only control up to 32 network addresses.



**Typical Systems**

These diagrams represent typical systems which are included as reference designs. Systems may deviate from what is shown herein, however, the principals remain sound. Select a system which closely represents system to be installed, then extend it as necessary. For questions or specific application help, please contact a Leviton sales representative or Leviton Technical Support directly at (800) 959-6004. When inquiring about a specific system it is helpful to have the Leviton bill of materials or equipment list for your particular project.

