

INSTALLATION INSTRUCTIONS

4" LED INSERTS
Rated Voltage 120V, 60Hz

Please read carefully and save these instructions as you may need them at a later date.

WARNING - RISK OF ELECTRIC SHOCK. DISCONNECT MAIN POWER AT FUSE OR CIRCUIT BREAKER BEFORE INSTALLING OR SERVICING THE FIXTURE.

GENERAL: All electrical connections must be in accordance with local and National Electrical Code (N.E.C.) standards. If you are unfamiliar with proper electrical wiring connections obtain the services of a qualified electrician.

Remove the KIT from the box and make sure that no parts are missing by referencing the PARTS illustrations.

THIS RETROFIT ASSEMBLY IS ACCEPTED AS A COMPONENT OF A LED LUMINAIRE WHERE THE SUITABILITY OF THE COMBINATION SHALL BE DETERMINED BY CSA OR CANADIAN AUTHORITIES HAVING JURISDICTION.

THIS DEVICE IS NOT INTENDED FOR USE WITH EMERGENCY EXITS.

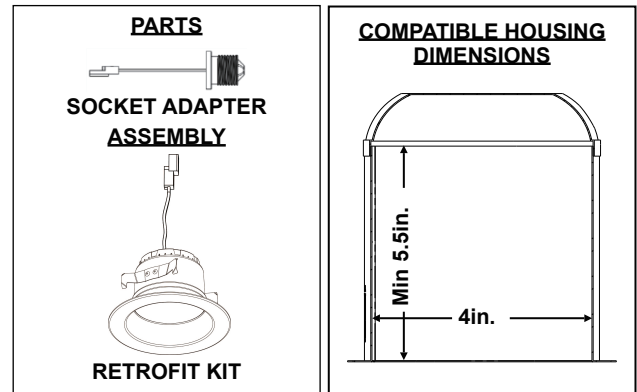

WARNING- RISK OF FIRE OR ELECTRIC SHOCK

- LED Retrofit Kit installation requires knowledge of luminaires electrical systems. If not qualified, do not attempt installation. Contact a qualified electrician.
- Install this kit only in luminaires that have the construction features and dimensions shown in the photographs and/or drawings and where the input rating of the retrofit kit does not exceed the input rating of the luminaire.
- Do not make or alter any open holes in an enclosure of wiring or electrical components during kit installation.
- To prevent wiring damage or abrasion, do not expose wiring to edges of sheet metal or other sharp objects.
- The inside of the ceiling must be waterproof.

ASSEMBLY AND INSTALLATION

INCANDESCENT HOUSINGS

1. Unscrew the WING NUT inside the CAN to detach the SOCKET BRACKET from the CAN. Disengage the SOCKET from the SOCKET BRACKET. **(FIG. 1)**
2. Thread the SOCKET ADAPTER into the SOCKET. **(FIG. 2)**
3. Plug the FEMALE CONNECTOR of the RETROFIT KIT onto the MALE CONNECTOR of the SOCKET ADAPTER ASSEMBLY. **(FIG. 3)**
4. Squeeze both FRICTION BLADES arms together and insert into the CAN. **(FIG. 4)**
5. Tuck all wires into the CAN and carefully push the RETROFIT KIT into CAN. (NOTE: To provide enough room in shallow cans, carefully position SOCKET ADAPTER and SOCKET adjacent to the side of the LED DRIVER prior to inserting the RETROFIT KIT into the CAN.) **(FIG. 2 & 4)**

LED HOUSINGS

1. Plug the FEMALE CONNECTOR of the RETROFIT KIT onto the MALE CONNECTOR of the LED HOUSING. **(FIG. 4)**
2. Squeeze both FRICTION BLADES arms together and insert into the CAN. Tuck all wires into the CAN and carefully push the RETROFIT KIT into CAN. **(FIG. 2 & 4)**

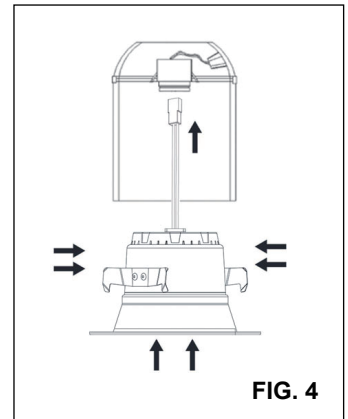
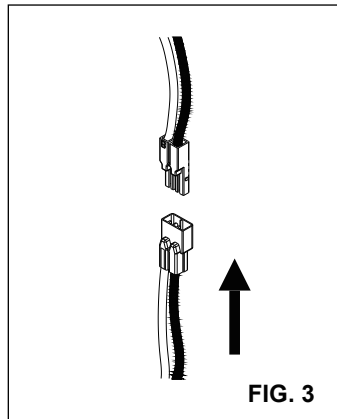
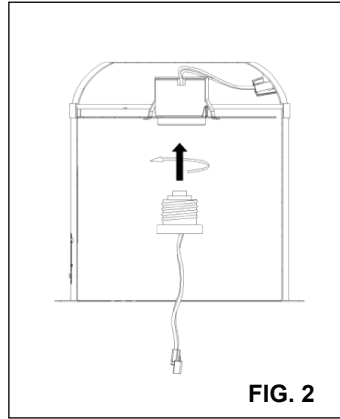
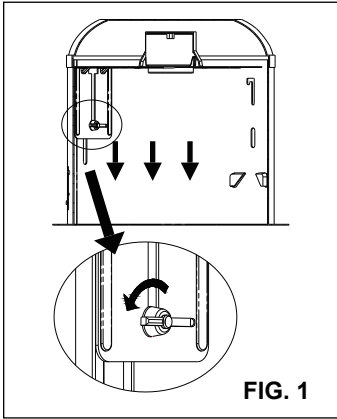

DIMMING

Dimming performance may depend on the dimmer, the dimmer range adjustment setting (for dimmers with brightness range adjustments), the wiring method, and/or the number of LED modules installed onto the dimmer circuit.

- For dimmer selection, it is recommended to use one of the following dimmers:
Lutron-TGCL-153P, DVCL-153P, CTCL-153P, MACL-153M, PD-6WCL
Leviton-IPL06-10, 6672-1L, 6674-PO
- For best results, it is recommended to install a minimum of four LED modules onto one dimmer.
- Before turning on the LED lights, set dimmer position at maximum before adjusting to a lower light level.
- Please follow the dimming control manufacturer's instructions for the installation of all dimming controls.

