

# INSTRUCTIONS

## WPLED® FIELD-ADJUSTABLE INSTALLATION



RAB Lighting is committed to creating high-quality, affordable, well-designed and energy-efficient LED lighting and controls that make it easy for electricians to install and end users to save energy. We'd love to hear your comments. Please call the Marketing Department at 888-RAB-1000 or email: [marketing@rablighting.com](mailto:marketing@rablighting.com)



WPLED - Small



WPLED - Medium



### IMPORTANT

#### READ CAREFULLY BEFORE INSTALLING FIXTURE. RETAIN THESE INSTRUCTIONS FOR FUTURE REFERENCE.

RAB fixtures must be wired in accordance with the National Electrical Code and all applicable local codes. Proper grounding is required for safety. THIS PRODUCT MUST BE INSTALLED IN ACCORDANCE WITH THE APPLICABLE INSTALLATION CODE BY A PERSON FAMILIAR WITH THE CONSTRUCTION AND OPERATION OF THE PRODUCT AND THE HAZARDS INVOLVED.

**WARNING:** Make certain power is OFF before installing or maintaining fixture. No user serviceable parts inside.

**CAUTION:** For proper weatherproof function all gaskets must be seated properly and all screws inserted and tightened firmly. Apply weatherproof silicone sealant around the edge of the Junction Box. This is especially important with an uneven wall surface. Silicone all plugs and unused conduit entries.

Suitable for wet locations as a downlight.

Suitable for wet locations as an uplight ONLY WHEN MOUNTED using the following accessories;  
**ARM24S, ARM24M, ARM24SVS, ARM24SVM, SWIVEL65S, SWIVEL65M**

### WALL MOUNT

1. Loosen (2) Door Screws and open Door as shown in Fig. 1.
2. Loosen (1) Cleat Screw. Separate Cleat/Door Assembly from fixture. Set desired Color Temperature (CCT), Power (W) and/or Photocell ON/OFF position (see Field Adjustment instructions Fig. 7 & 8).
3. Secure Cleat/Door Assembly to the mounting surface using hardware (by others) appropriate for the mounting surface.
4. Slide fixture on Cleat/Door Assembly. Secure using (1) Cleat Screw.
5. Wire the fixture using UL listed wire connectors according to NEC and local codes. See wiring diagram, Fig. 9, 10.
6. Close door and tighten (2) Door Screws.
7. Apply silicone sealer around the fixture where it meets the wall to prevent water entry.

Fig: 1

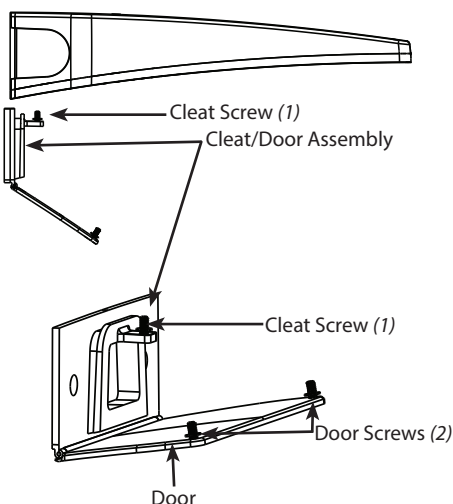

### SURFACE MOUNT FOR RECESSED BOX

For use with recessed Junction Box (by others), optional use for surface mounting.

1. Use supplied Crossbar and attach to Junction Box (by others) as shown in Fig. 2.
2. Loosen (2) Door Screws and open Door.
3. Loosen (1) Cleat Screw. Separate Cleat/Door Assembly from fixture. Set desired Color Temperature (CCT), Power (W) and/or Photocell ON/OFF position (see Field Adjustment instructions Fig. 7 & 8).
4. Secure Cleat/Door Assembly to Wall Plate (provided) using (2) Screws (provided).
5. Use 1/4" x 20 stainless steel Mounting Screw (provided) to attach Wall Plate to Crossbar.
6. Insert Plug (provided) to cover Mounting Screw.
7. Slide Fixture on Cleat/Door Assembly and secure using (1) Cleat Screw.
8. Wire the fixture using UL listed wire connectors according to NEC and local codes (see Fig. 9, 10).
9. Close Door and tighten (2) Door Screws.
10. Apply silicone sealer around the Wall Plate where it meets the wall to prevent water entry.

Fig: 2

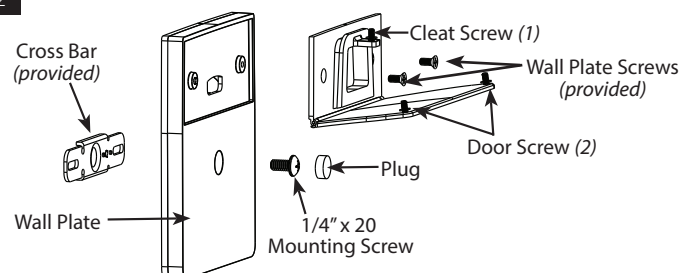

# INSTRUCTIONS

## WPLED® FIELD-ADJUSTABLE INSTALLATION



RAB Lighting is committed to creating high-quality, affordable, well-designed and energy-efficient LED lighting and controls that make it easy for electricians to install and end users to save energy. We'd love to hear your comments. Please call the Marketing Department at 888-RAB-1000 or email: marketing@rablighting.com

### ACCESSORIES

(Accessories sold separately)

WPLEDS: ARM24S, ARM24SVS, SWIVEL65S

WPLEDM: ARM24M, ARM24SVM, SWIVEL65M

### ARM24

CAUTION: Use mounting hardware appropriate for the mounting surface and weight of the fixture.

1. Make supply connections in recessed **Junction Box**.
2. Mount **Wall Plate** to wall through (4) **Mounting Holes** using appropriate hardware for your mounting surface.
3. Mount fixture on other end of **ARM24** (see **accessory list above**). Works with any 1/2" NPS threaded mounting (Fig. 3).
4. Tighten **Set Screws** and all other screws and hardware.
5. To ensure weatherproof seal, apply weatherproof silicone sealant to all unused plugs and holes and all along the edge of the **Wall Plate**. Use Teflon® tape or use weatherproof silicone sealant on **ARM24** threads.

Fig: 3

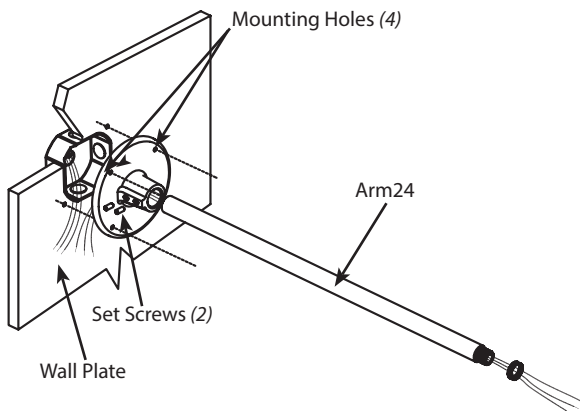

### ARM24 (UPLIGHT MOUNT)

1. Loosen (2) **Door Screws** and (1) **Cleat Screw** (Fig. 4). Separate and discard **Cleat** and **Door Assembly** from fixture. Set desired Color Temperature (CCT), Power (W) and/or Photocell On/Off position (see *Field Adjustment instructions Fig. 7 & 8*).
2. For **ARM24** or **ARM24SV**, secure new **Cleat Assembly** to threaded rod. For **Swivel65** secure **Cleat Assembly** to the mounting surface (Fig. 6) using hardware (by others) appropriate for the mounting surface. See **ARM24** instructions for sealing of threads and wall mount.
3. Slide fixture on new **Cleat Assembly**. Secure using (1) **Cleat Screw** (Fig. 5).
4. Wire the fixture using UL listed wire connectors according to NEC and local codes. See wiring diagram (Fix 9, 10).
5. Secure **Door** and tighten (3) **Door Screws**.

Fig:4

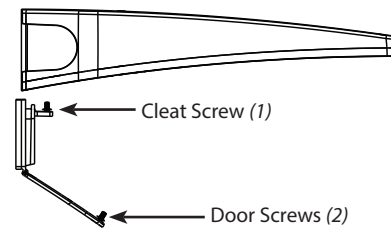

Fig: 5

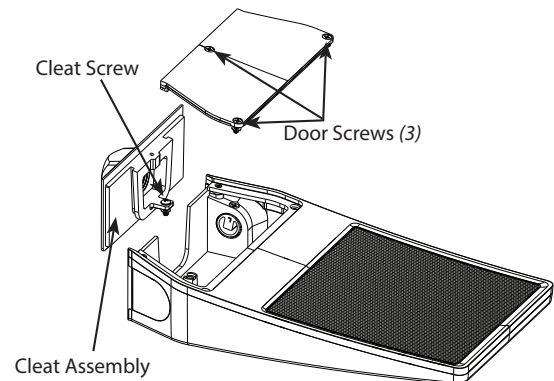
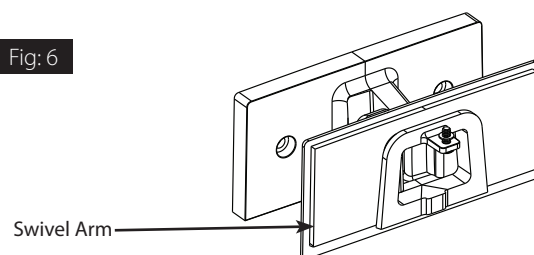

Fig: 6



# INSTRUCTIONS

## WPLED® FIELD-ADJUSTABLE INSTALLATION



RAB Lighting is committed to creating high-quality, affordable, well-designed and energy-efficient LED lighting and controls that make it easy for electricians to install and end users to save energy. We'd love to hear your comments. Please call the Marketing Department at 888-RAB-1000 or email: marketing@rablighting.com

### FIELD ADJUSTMENT

#### Photocell Operation:

This product is equipped with a photocell. **Photocell factory setting is set to the "OFF" position.** Should you wish to enable the Photocell "ON" feature slide the center switch to the "ON" position (Fig 3 & 4). ***If the Photocell is set to the "ON" position and it is daylight it may take up to 60-seconds for the light to turn off.***

#### Color Temperature (CCT) Selection:

This product is equipped with 3000K, 4000K or 5000K (CCT) **Color Temperature** selection. For maximum light output use the 4000K Color Temperature.

#### Power (Wattage) Selection:

This product is equipped with power output selection.

WPLEDS 13/10/6W

WPLEDM 32/24/16W

Follow instructions below to change **Color Temperature (CCT)**, **Power (W)** and/or **Photocell** operation from factory settings.

**Factory Settings: WPLEDS 10W / 4000K / Photocell/OFF**

**WPLEDM 24W / 4000K / Photocell/OFF**

1. Locate the **Selector Switches** inside of housing as shown in Fig. 7, 8.
2. Select **Color Temperature (CCT)**, **Power (W)** and/or **Photocell ON/OFF** function by sliding the respective switch to the desired value (Fig. 8).

### 0-10V DIMMABLE WIRING

Universal voltage driver permits operation at 120V through 277V 50 or 60 Hz. For 0-10V dimming follow the wiring directions as shown in Fig. 9 and 10.

1. Connect the black fixture lead to the **LINE** supply lead.
2. Connect the white fixture lead to the **COMMON** supply lead.
3. Connect the **GROUND** wire from fixture to supply ground.
4. Connect the purple fixture lead to the (V+) DIM lead.
5. Connect the pink fixture lead to the (V-) DIM lead.
6. Cap the Purple/White and Black/White fixture leads. **DO NOT** connect.

**NOTE:** Do not connect DIM V+ (purple)/ DIM V- (pink) to line voltage or supply ground.

Fig: 9

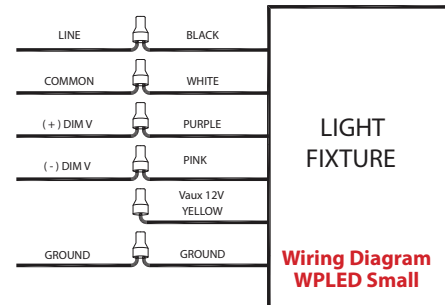

Fig: 10

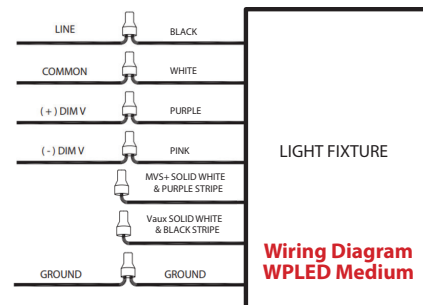

Fig: 7

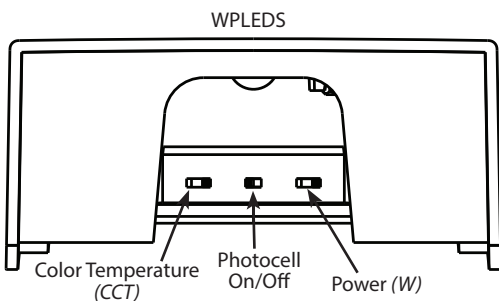
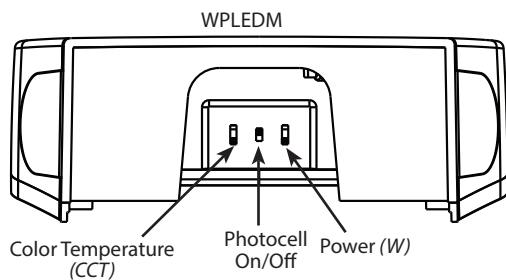

Fig: 8



# INSTRUCTIONS

## WPLED® FIELD-ADJUSTABLE INSTALLATION



RAB Lighting is committed to creating high-quality, affordable, well-designed and energy-efficient LED lighting and controls that make it easy for electricians to install and end users to save energy. We'd love to hear your comments. Please call the Marketing Department at 888-RAB-1000 or email: marketing@rablighting.com

### LCBS/MVS WIRING (AVAILABLE FOR MEDIUM SIZE ONLY)

Universal voltage driver permits operation at 120V through 277V 50 or 60 Hz. For **LCBS/MVS** wiring follow the wiring directions as shown in Fig. 11.

1. Connect the black fixture lead to the **LINE** supply lead.
2. Connect the white fixture lead to the **COMMON** supply lead.
3. Connect the **GROUND** wire from fixture to supply ground.
4. Connect the pink fixture lead to the pink **LCBS/MVS** lead.
5. Connect the purple/white **MVS+** fixture lead to the purple **LCBS/MVS** lead.
6. Connect the black/white fixture lead to the black/white **LCBS/MVS** lead.
7. Cap the purple fixture lead if present. **DO NOT** connect.

**NOTE:** Do not connect DIM V+ (purple)/ DIM V- (pink) to line voltage or supply ground.

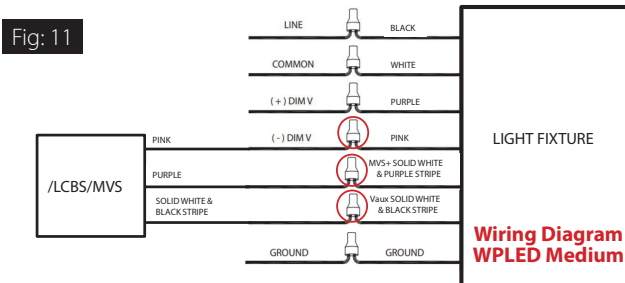

### CLEANING & MAINTENANCE

**CAUTION:** Be sure fixture temperature is cool enough to touch. Do not clean or maintain while fixture is energized.

1. Clean lens with non-abrasive glass cleaning solution.
2. Do not open the fixture to clean the LED. Do not touch the LED.

### TROUBLESHOOTING

1. Check that the line voltage at the fixture is correct. Refer to wiring directions.
2. Is the fixture grounded properly?
3. Is the photocell, if used, functioning properly?

**Note:** These instructions do not cover all details or variations in equipment nor do they provide for every possible situation during installation, operation or maintenance.

# INSTRUCTIONS

## WPLED® FIELD-ADJUSTABLE INSTALLATION



RAB Lighting is committed to creating high-quality, affordable, well-designed and energy-efficient LED lighting and controls that make it easy for electricians to install and end users to save energy. We'd love to hear your comments. Please call the Marketing Department at 888-RAB-1000 or email: marketing@rablighting.com

# BATTERY BACKUP MODELS

## WALL MOUNT

1. Loosen (2) **Door Screws** and open **Door** as shown in Fig. 12.
2. Feed supply wires from the wall through the **Battery Box** and into the fixture wiring compartment.
3. Secure **Battery/Fixture** assembly to the mounting surface using hardware (*by others*) appropriate for the mounting surface.
4. Insert **Plug** (*provided*) to cover **Mounting Screw**.
5. Follow wire up instructions as shown in Fig. 13.
6. Close **Door** and tighten (2) **Screws**.
7. Apply silicone sealer around the fixture where it meets the wall to prevent water entry.

## SURFACE MOUNT FOR RECESSED BOX

For use with recessed Junction Box (*by others*), optional use for surface mounting.

1. Loosen (2) **Door Screws** and open **Door** as shown in Fig. X.
2. Feed supply wires from the wall through the **Battery Box** and into the fixture wiring compartment.
3. Use supplied **Crossbar** and 1/4 x 20 Mounting Screw to attach the **Junction Box** (*by others*) as shown in Fig. 12 (*use the bottom mounting hole for additional mounding hardware (by others) appropriate for the mounting surface if necessary.*)
4. Insert **Plug** (*provided*) to cover **Mounting Screw**.
5. Follow wire up instructions as shown in Fig. 13
6. Close Door and tighten (2) **Screw**.
7. Apply silicone sealer around the fixture where it meets the wall to prevent water entry.

Fig: 12

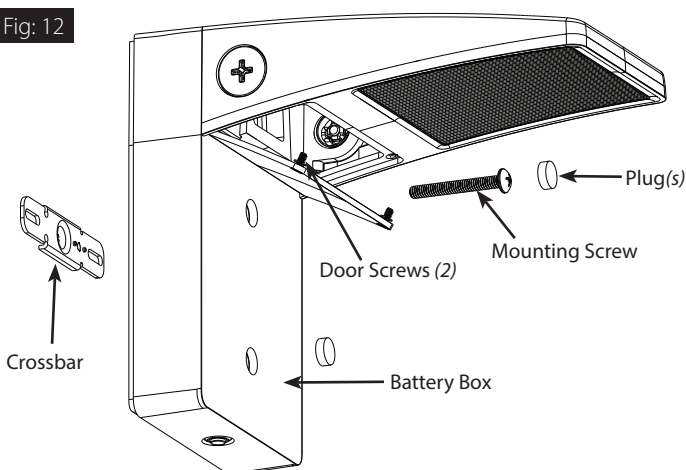

## WIRING

**CAUTION: FOR BATTERY BACKUP FIXTURE.** Voltage can be present in **BATTERY**. **NOTE:** Make sure that the necessary branch circuit wiring is available. An **UNSWITCHED AC** source of power is required. The emergency driver must be fed from the same branch circuit as the LED driver.

**CAUTION:** Do not use any supply voltage other than 120-277V, 50/60 Hz.

1. Connect **UNSWITCHED HOT** fixture lead to **HOT AC** supply line.
2. If using an **UNSWITCHED** circuit, connect **UNSWITCHED** and **SWITCHED** lines together.
3. If using a **SWITCHED** circuit, connect **SWITCHED HOT** AC fixture lead to the external.
4. For 0-10V dimming, connect **DIM (+)** purple and **DIM (-)** pink leads to dimming connections.
5. All unused leads must be capped and insulated.
6. After installation is complete, supply AC power to the fixture.
7. When power is on, the fixture should be on and the **CHARGING INDICATOR LIGHT** should illuminate to indicate the battery is charging.
8. Once the **BATTERY** has charged for at least one hour, a short duration test may be performed by pressing the **Test Button** as shown in Fig. 14.
9. After the battery has charged for 24 hours, a long duration test can be performed by disconnecting power to the fixture.

Fig: 13

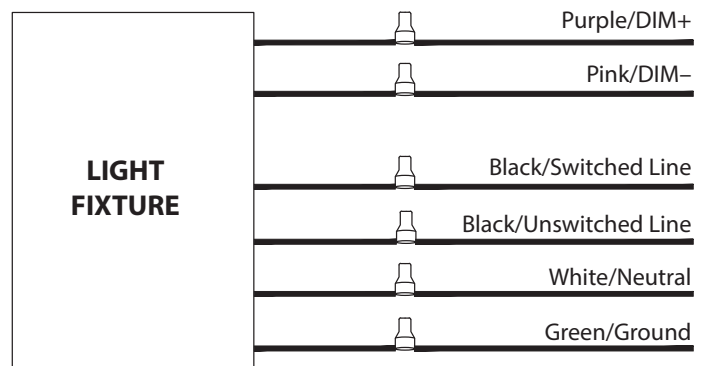

# INSTRUCTIONS

## WPLED® FIELD-ADJUSTABLE INSTALLATION



RAB Lighting is committed to creating high-quality, affordable, well-designed and energy-efficient LED lighting and controls that make it easy for electricians to install and end users to save energy. We'd love to hear your comments. Please call the Marketing Department at 888-RAB-1000 or email: [marketing@rablighting.com](mailto:marketing@rablighting.com)

### TROUBLESHOOTING

---

1. Be sure the fixture is grounded properly.
2. If the charging indicator light does not illuminate after pressing the **Test Button** (Fig. 14), check if battery is connected properly.

FIG. 14

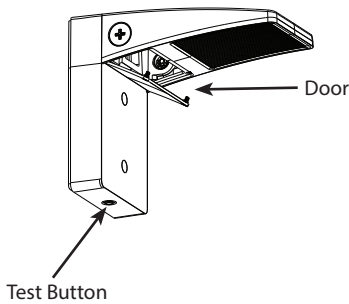

### OPERATION

---

1. When AC power is applied the charging indicator light is illuminated indicating that the **BATTERY** is being charged.
2. When power fails the standby power automatically switches to emergency power (*internal battery*) operating at reduced illumination.
3. When AC power is restored the emergency driver automatically returns to charging mode.

### MAINTENANCE

---

Although no routine maintenance is required to keep the emergency driver functional, it should be checked periodically to ensure that it is working. The following schedule is recommended:

1. Visually inspect the charging indicator light monthly. It should be illuminated
2. Test the emergency operation of the fixture at 30-day intervals for a minimum of 30 seconds.
3. Conduct a 90-minute discharge test once a year. Fixture would operate at reduced illumination for a minimum of 90 minutes.

### TROUBLESHOOTING

---

1. Check that the line voltage at the fixture is correct. Refer to wiring directions.
2. Be sure the fixture is grounded properly.
3. Is the photocell, if used, functioning properly?



© 2025 RAB LIGHTING Inc.

WPLED S/M - IN - 0125  
P-101023

#### Easy Answers

[rablighting.com](http://rablighting.com)  
Visit our website for product info

**Tech Help Line**  
Call our experts: 888 722-1000

**e-mail**  
Answered promptly - [tech@rablighting.com](mailto:tech@rablighting.com)

**Free Lighting Layouts**  
Answered online or by request

**RAB WARRANTY:** RAB's warranty is subject to all terms and conditions found at [rablighting.com/warranty](http://rablighting.com/warranty).