

Vive Wireless Hub

The Vive hub provides a connection point for Lutron Vive devices such as PowPak wireless dimming and switching modules, PowPak Wireless Fixture Controllers, PowPak 20 A Relay Modules, Maestro Wireless dimmers and switches, Wireless Receptacle controls, Pico remote controls, Radio Powr Savr occupancy sensors, and daylight sensors. For a complete list of compatible devices, see the last page of this document.

For more information on the Vive hub, including training materials, design information and software updates, please visit www.lutron.com/vive

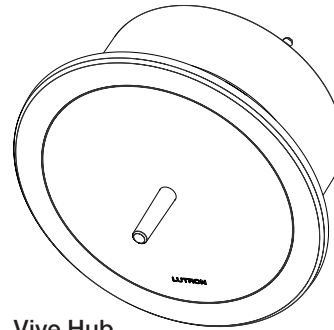

Vive Hub

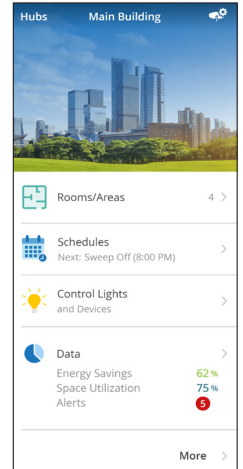

Vive Hub Dashboard

Features

- Can be easily programmed with any Wi-Fi enabled iOS® or Android® compatible device using the free Lutron Vive app (available for download from the App Store or Google Play®) or by using web-based software.
- iOS® and Android® Apps – Helper apps act as an intermediary between Vive systems and the Lutron Cloud without the need of a permanent internet connection. It connects to hubs when on-site and passes data back and forth when the smart device reconnects to the Internet. Visit www.lutron.com/VivePrivacyNotice for more about this data.
 - Registration of jobs/users for extended warranty.
 - Manage multiple jobs with contacts and job info.
 - Invite facility users to have access to hubs/job.
 - Automatically send handoff documentation personalized to your firm to facility management team, including programming user guide, online "How-to" videos, and support number.
 - Connection to hub browser user interface for setup. Normal web browser still works and the app is not required.
 - Connection to hub browser dashboard for control and monitor. Normal web browser still works and the app is not required.
 - Backup the database to the Lutron Cloud for hub replacement.
 - Download reports that list the inventory of hubs and devices commissioned in your job.
- Communicates with controls on a floor using Lutron wireless Clear Connect technology.
- Distributed system architecture.
 - Wireless sensors and controls must be located within 60 ft (18 m) line of sight, or 30 ft (9 m) through walls, of the associated device.
- Supports timeclock events based on both sunrise and sunset or fixed time-of-day.
- Timeclock events can control individual devices, areas, or groups of areas.
 - Note: This feature is not available once a hub is paired with a Vive Vue server.
- Uses Lutron RF signal strength measurements to find devices nearby for quick association and programming without having to climb ladders.
- Dashboard of current status for control and monitoring of the system. Also shows current energy usage.
- Integrated multi-color LED provides feedback on what mode the hub is in.
- Connects directly to any smartphone, tablet or computer using built in Wi-Fi. 2.4 GHz 802.11b/g. using WPA2 Security.
- Each hub presents a dashboard of devices and areas which it controls.

continued on next page . . .

Job Name: <input type="text"/>	Model Numbers: <input type="text"/>	
Job Number: <input type="text"/>	<input type="text"/>	<input type="text"/>

Features (continued)

- If all the hubs on a job are networked using Ethernet, you can easily navigate from one hub to another to view its dashboard.
- Ethernet 10/100 Mbps connection for:
 - Native BACnet®/IP (see Lutron P/N 369996 at www.lutron.com for PIC Statement) integration into Building Management Systems (HJS-2-XX only). The Vive Hub has been tested by BACnet® Testing Laboratories (BTL) and is certified to comply with all necessary interoperability requirements.
 - Network multiple Vive hubs together as an independent system or as part of an existing building network.
 - Native OpenADR® support, to manage Automatic Demand Response/Load Shed events dictated by a utility company.
 - Each Vive hub hosts a unique virtual BACnet® network. As such, each Vive hub requires a unique BACnet® network number.
- Firmware upgradable for future features and security patches.
- Password protected access.
- Flush-mount or surface-mount options available.
- Supported on most devices that use an HTML5 compliant browser (iOS®, Android®, Windows®, Mac).
- Required browsers are Google® Chrome® and Safari.
- Supports HTTPS.
- Recommended configurations for smart devices:

Device	OS Version
iPhone 6, iPhone 6 plus or newer	iOS® 11.0 or later
Supported on most Android® devices running Android® 6.0 or later.	Android® 6.0 or later

- Daylighting Setpoint Tweaking – If the lights are too bright or too dim while using daylighting, adjust the settings in real time from a smart device to alter the setpoint for the light level that is maintained between natural and electric light. Older devices (released prior to September 2017) can be adjusted but may take a minute to reach desired level because of a slow fade. New devices will respond immediately.

- Daylighting-to-Low-End or Daylighting-to-Off – The Vive system will allow the user to select either daylighting-to-low-end or daylighting-to-off on an area by area basis.
 - Requires Vive hub software 01.08 or higher.
- Customer Supplied Security Certificates
 - Provides customers the ability to load their own authentication certificates for their specific domain.
 - Provides customers using the Vive hub application to use secure browser communications without receiving any authentication warnings due to the self-signed certificates that are shipped with the hubs.
 - Requires Vive hub software 01.08 or higher.
- Timeclock Occupancy Sensor Settings Changes
 - Requires devices shipped after September 2017. Devices shipped prior to that date will be displayed as "unsupported" in the software UI. Allows timeclock events to change the behavior of occupancy settings based on time of day. For example, change the unoccupied level of corridors/hallways from 25% during the day, and off at night. The following settings can be changed:
 - Occupied Level – The level the lights go to when occupied. Changes are not applied immediately to currently occupied spaces, but will change the next time the space goes occupied to minimize distraction.
 - Unoccupied Level – The level the lights go to when unoccupied. Changes are applied immediately to spaces not currently occupied.
 - Enable/Disable Occupancy – Change whether devices will respond to the occupancy sensor.
 - Timeout of the sensors (requires FC-VSENSOR). LRF2 sensors still require this setting to be set on the sensor.
- 365-day schedulable timeclock with exceptions for holidays.
 - Allows scheduling events 10 years in advance.
 - Set recurring events with exceptions on holidays.
 - Allows scheduling events on specific day of the year.

continued on next page...

Job Name:	Model Numbers:	
<input type="text"/>	<input type="text"/>	<input type="text"/>
Job Number:	<input type="text"/>	<input type="text"/>

Features *(continued)*

- Measured energy data for PowPak Wireless Fixture Control accurate to ±2% or 0.5 W, whichever is higher.
- Measured energy data is available for the Vive Integral Fixture Control when paired with a driver that supports measured power. See Lutron specification submittal (P/N 3691039) at www.lutron.com for more information.
- Provides calculated energy data for PowPak modules and Maestro dimmers or switches.
- Create and edit areas.
- Tune area light levels by trimming the high-end and low-end output to save energy.
- Adjust occupancy settings. Create occupancy groups.
- Can extend the RF range of up to 15 Pico remote controls per Vive hub. These remotes can be set up to control any device within the 71 ft (22 m) range of that Vive hub.
- RF range of occupancy sensors can be extended for up to 14 areas per Vive hub. In a range extended area, an occupancy sensor can control any device in that area, regardless of distance between sensor and device. Requires Vive hub software 01.09 or higher.
- Configurable Fade Time
 - Up to 90 minutes for timeclock events and scenes.
 - Limited to 90 seconds for FCJS-ECO, FCJS-ECO-EM, RMJS-ECO32-SZ, DFCSJ-OEM-RF, and DFCSJ-OEM-OCC devices.
 - NOTE: This feature is not available once a hub is paired with a Vive Vue server.
 - Up to 90 seconds for Pico remote control programming.
 - Fade time may differ between buttons on the same Pico remote control.
 - Single fade time applies to all programming for a button.
- Automatic Demand Response/Load Shed
 - Load Shedding will physically dim the lights to a programmable level to help meet the requirements for the California Title 24 Building Energy Efficiency Standards–Automatic Demand Response.
 - OpenADR® 2.0b compliant (requires Vive hub software 01.09 or higher).
 - May be enabled (or disabled) via any of the following methods:
 - The first contact closure input (CCI 1)
 - BACnet® integration
 - OpenADR® integration
 - OpenADR® requires access to utility companies over the Internet, so the hub must be connected via Ethernet to use OpenADR®.
- Alerts
 - View run-time issues which may prevent devices from operating as expected, such as low batteries or missing devices.
- API Integration
 - To integrate with third-party devices, systems, and software, RESTful APIs are available over the Ethernet.
- Scenes
 - Scenes can control individual devices, areas, or groups of areas on demand.
 - May be activated via any of the following methods:
 - The second contact closure input (CCI 2)
 - API integration
 - Manual activation in the app
 - Maximum of 50 scenes are supported.
 - Requires Vive hub software 01.13 or higher.

continued on next page . . .

Job Name: <input type="text"/>	Model Numbers: <input type="text"/>	
Job Number: <input type="text"/>	<input type="text"/>	<input type="text"/>

Features (continued)

- Override and lockout support for the emergency devices.
 - Activate override and lockout manually, using LUT-ELI-3PH or with an integration device such as a fire alarm. This will send the emergency lights to the defined levels and lock out the controls (Pico remotes and sensors) in the case of a fire alarm or security incident.
 - May be activated via any of the following methods:
 - The second contact closure input (CCI 2)
 - API integration
 - Manual activation in the app
 - Supports all red-label emergency PowPak devices.
 - Requires Vive hub software 01.13 or higher.
- Note:** Vive hub has been evaluated by UL for use in emergency lighting systems in accordance with standard UL 924 when paired with the LUT-ELI-3PH Emergency Lighting Interface. Requires Vive hub software 01.13 or higher.
- Programmable CCI
 - The second contact closure input (CCI 2) can be programmed to activate a scene or override and lockout emergency devices in case of a fire alarm.
 - Scene activation
 - Set a scene to activate using the second contact closure input (CCI 2) on the Vive hub.
 - Override & Lockout support activation (fire alarm, security incident)
 - Provides the ability to command all red-label emergency load controllers to programmable light levels and lockout the controls.
 - Requires Vive hub software 01.13 or higher
- Occupancy Dependency
 - Occupancy sensors in one room/area can control devices in other rooms/areas.
 - Radio Powr Savr occupancy sensors and Maestro Wireless 0–10 V== dimmers and switches with sensor only.
 - Requires Vive hub software 01.14 or higher
- Staged Occupancy
 - Enable zones in an area to go to a dimmed light level (typically 20%) when unoccupied. When all zones in the area go unoccupied, all lights will turn off. Upon initial occupancy of the area, the occupied zone will go to the occupied light level and the unoccupied zones will all go to a dimmed light level (typically 20%).
 - Requires Vive hub software 01.20 or higher.
- Manually select dimming module phase in the app (supported devices only).

Job Name: <input style="width: 90%;" type="text"/>	Model Numbers: <input style="width: 60%;" type="text"/> <input style="width: 35%;" type="text"/>	
Job Number: <input style="width: 150px;" type="text"/>	<input style="width: 300px;" type="text"/>	<input style="width: 300px;" type="text"/>

Specifications

Regulatory Approvals

- cULus Listed
- FCC approved. Complies with the limits for a Class B device, pursuant to Part 15 of the FCC rules.
- IC
- COFETEL
- NOM

Power/Performance

- Input to power supply:
120 – 277 V~ 50/60 Hz 0.6 A
- Input to Vive hub:
24 V== 350 mA

System Limits

- HJS-1, HJS-2 support up to 700 Lutron Wireless devices. HJS-0 supports 75 Lutron Wireless devices. Devices must be located within 71 ft (22 m) of the Vive hub.
- Any given load device can be controlled by 10 occupancy sensors, 10 Pico remote controls and 1 daylight sensor (Pico remote controls and sensors must be located within 30 ft [9 m] of the load device they are controlling).

Mounting

- Vive hub units should be mounted in the middle of non-metal ceiling tile or drywall, visible from inside the space.
- Installation near metal, other than a junction box, may reduce RF range. Hub should be at least 12 in (305 mm) away from metal objects.
- Use surface-mount version for mounting to a hard or cement ceiling.
- Power supply mounts to a standard 4 in x 4 in (101 mm x 101 mm) square junction box.
- Power supply must be mounted within 100 ft (31 m) of the Vive hub. Wiring should be 24 AWG to 12 AWG (0.2 mm² to 2.5 mm²).

Environment

- For indoor use only.
- 32 to 104 °F (0 to 40 °C).
- Relative humidity less than 90% non-condensing.

Contact Closure Input Terminals

- First contact closure input (CCI 1) is to be used for initiating load shed only. Load shedding will physically dim the lights to a programmable level to help meet the requirements for The California Title 24 Building Energy Efficiency Standards Automatic Demand Response.
- The second contact closure input (CCI 2) may be programmed to activate an emergency or scene. If activating a scene, a "deactivation" behavior may be set in the scene in order to set two behaviors for the one input.
- Accepts only maintained inputs.
- Off-state leakage current must be less than 100 µA.
- Open circuit voltage: 24 V== maximum.
- Input wiring: 24 AWG to 12 AWG (0.2 mm² to 2.5 mm²).
- Contact Closure Inputs on multiple hubs can be wired in parallel. **DO NOT** wire inputs in parallel with other equipment as it can cause the inputs on either of the devices to falsely trigger.
- Up to 4 hubs in parallel.
- To ensure proper operation of Contact Closure Inputs, a PS-J-20W-UNV power supply may not be used to provide power to more than one hub.
- Inputs must be dry contact closure, solid state, open collector, or active-low (NPN)/active high (PNP) output.
 - Open collector NPN or active-low on-state voltage must be less than 2 V== and sink 3.0 mA.
 - Open collector PNP or active-high on-state voltage must be greater than 12 V== and source 3.0 mA.

Programming

- The Vive hub is meant to be permanently installed. It is **NOT** intended to be used as a programming tool that can be removed from the site after commissioning. Various Vive system features are dependent on the hub for proper functionality. In addition, users and other maintainers will be forced to recommission the entire system in order to make simple changes or additions if the hub is not installed on-site as part of the commissioned system.

Warranty

- For warranty information, please visit www.lutron.com/warranty or call 1.844.LUTRON1 for a printed copy.

Job Name: <input style="width: 90%;" type="text"/>	Model Numbers: <input style="width: 95%;" type="text"/>	
Job Number: <input style="width: 80%;" type="text"/>	<input style="width: 95%;" type="text"/>	<input style="width: 95%;" type="text"/>

How to Build a Model Number

Example

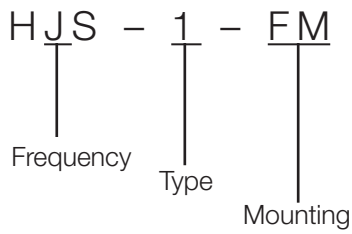

Frequency Band

J = 433.05–434.79 MHz

Type

- 0 = Starter Vive hub without BACnet® limited to 75 devices (Available as HJS-0-FM only)
- 1 = Vive hub without BACnet®
- 2 = Premium Vive hub with BACnet®

Mounting

- FM = Flush-Mount (non-metal ceiling tiles or drywall)
- SM = Surface-Mount (cement)

Available Vive Hub Model Numbers (includes power supply and mounting adapter)

- HJS-0-FM - Starter hub, flush-mount adapter and power supply
- HJS-1-FM - Vive hub, flush-mount adapter and power supply
- HJS-1-SM - Vive hub, surface-mount adapter and power supply
- HJS-2-FM - Premium Vive hub, flush-mount adapter and power supply
- HJS-2-SM - Premium Vive hub, surface-mount adapter and power supply
- HJS-UPDATE - Software upgrade license to add BACnet to HJS-0 and HJS-1 hubs
- HJS-DEVICES - Software upgrade license expands device limit to 700 devices for HJS-0 hubs

Replacement Part Model Numbers

- PS-J-20W-UNV Vive hub external power supply
- H-MOUNT-FM Flush-mount installation adapter
- H-MOUNT-SM Surface-mount installation adapter

Ethernet Switch Model Numbers (sold separately)

All switches are unmanaged 10/100/1000 Mbps. This IT gear is a suggested list. IT provided gear that is equivalent or better is sufficient. Enterprise level gear recommended.

- ETH-SWITCH-16 16 port
- ETH-SWITCH-24 24 port
- ETH-SWITCH-24-1M 24 port, 1 multi-mode fiber
- ETH-SWITCH-24-2M 24 port, 2 multi-mode fiber
- ETH-SWITCH-24-1S 24 port, 1 single-mode fiber
- ETH-SWITCH-24-2S 24 port, 2 single-mode fiber

Job Name: <input style="width: 90%; height: 20px;" type="text"/>	Model Numbers: <input style="width: 60%; height: 20px;" type="text"/> <input style="width: 35%; height: 20px;" type="text"/>	
Job Number: <input style="width: 150px; height: 20px;" type="text"/>	<input style="width: 300px; height: 20px;" type="text"/>	<input style="width: 300px; height: 20px;" type="text"/>

Dimensions

Dimensions are shown as: in (mm)

Vive Hub

Top View

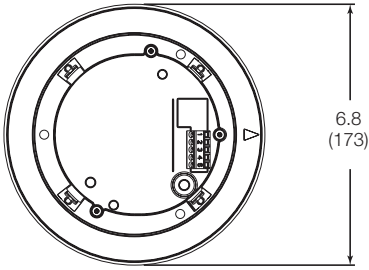

Side View

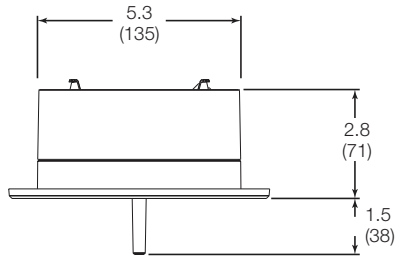

Flush-mount Adapter

Top View

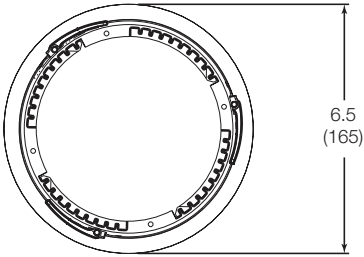

Side View

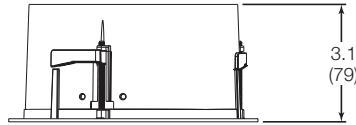

Flush-mount Adapter Details

- Requires a 6 in (153 mm) hole to be cut in the ceiling for mounting.

Surface-mount Adapter

Top View

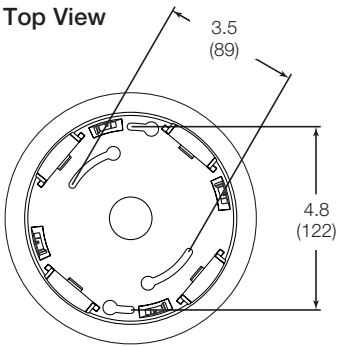

Side View

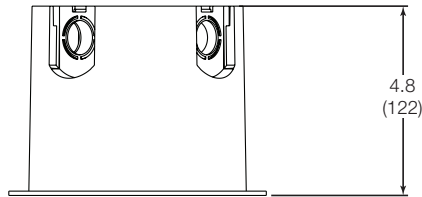

Surface-mount Adapter Details

- Knockouts for 1/2 in or 3/4 in (13 mm or 19 mm) conduit.

Power Supply

Top View

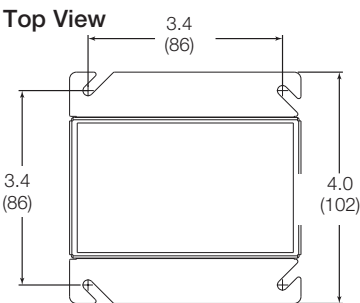

Side View

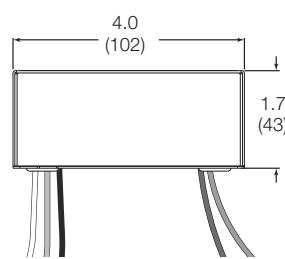

Job Name:	Model Numbers:	
<input type="text"/>	<input type="text"/>	<input type="text"/>
Job Number:	<input type="text"/>	<input type="text"/>

Range Diagrams

All wireless devices to be associated to the Vive hub must be within 71 ft (22 m) of the Vive hub and must be on the same floor as the Vive hub.

Note: Vive hubs should be mounted greater than 10 ft (3 m) apart on the same floor.

Note: A corporate Wi-Fi network can interfere with the Wi-Fi on the Vive hub. Where a corporate Wi-Fi network exists, it is recommended to do the following:

- Connect the Vive hub to the corporate network using the Ethernet connection on the hub and disable Wi-Fi on the hub.

Note: Vive hubs should be mounted greater than 10 ft (3 m) from a Wi-Fi router or access point.

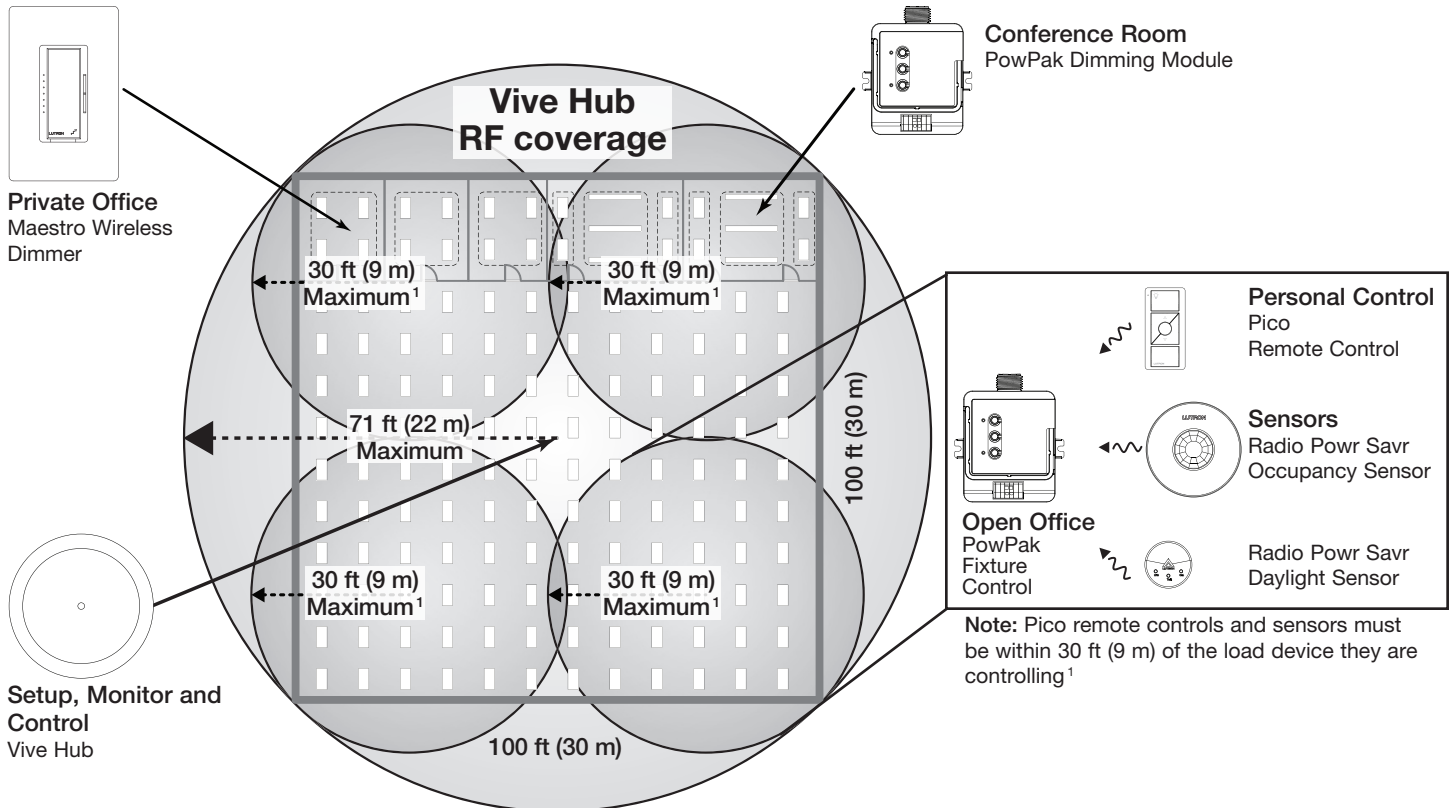

¹ Wireless sensors and controls must be located within 60 ft (18 m) line of sight, or 30 ft (9 m), through walls, of the associated device.

Range with multiple Vive hubs

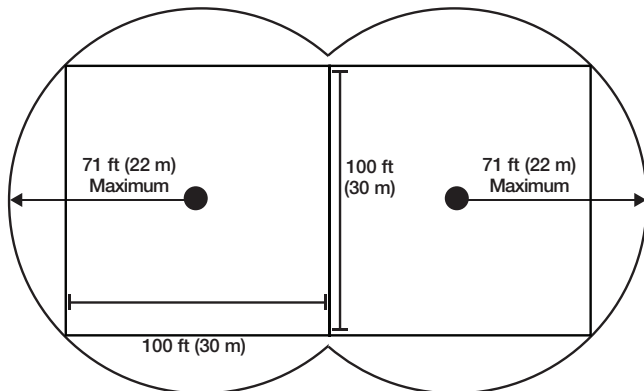

Job Name:	Model Numbers:	
<input type="text"/>	<input type="text"/>	<input type="text"/>
Job Number:	<input type="text"/>	<input type="text"/>

Wiring

Product Overview (Flush-mount adapter)

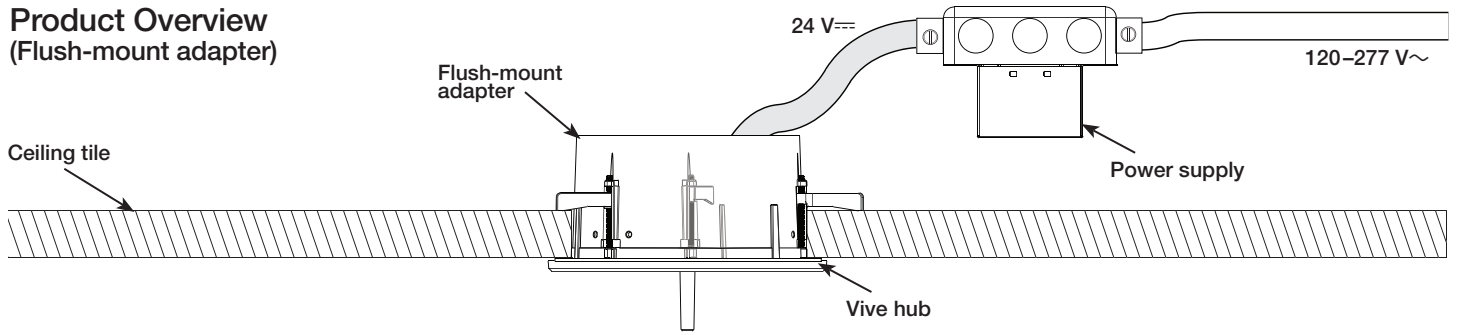

See Lutron Application Note #628 (P/N 048628) at www.lutron.com for information on wiring Emergency Lighting with a Vive System.

Product Overview (Surface-mount adapter)

Note: For Chicago plenum space applications the power supply has a metal enclosure and can be mounted in the plenum space. The Vive hub cannot be mounted in the plenum space and needs to be mounted outside the plenum space on the surface of the ceiling.

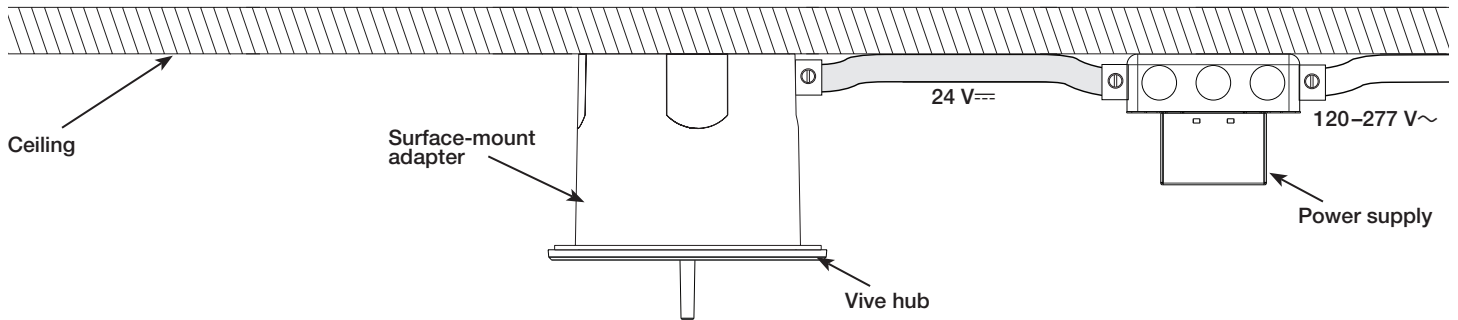

Vive Hub

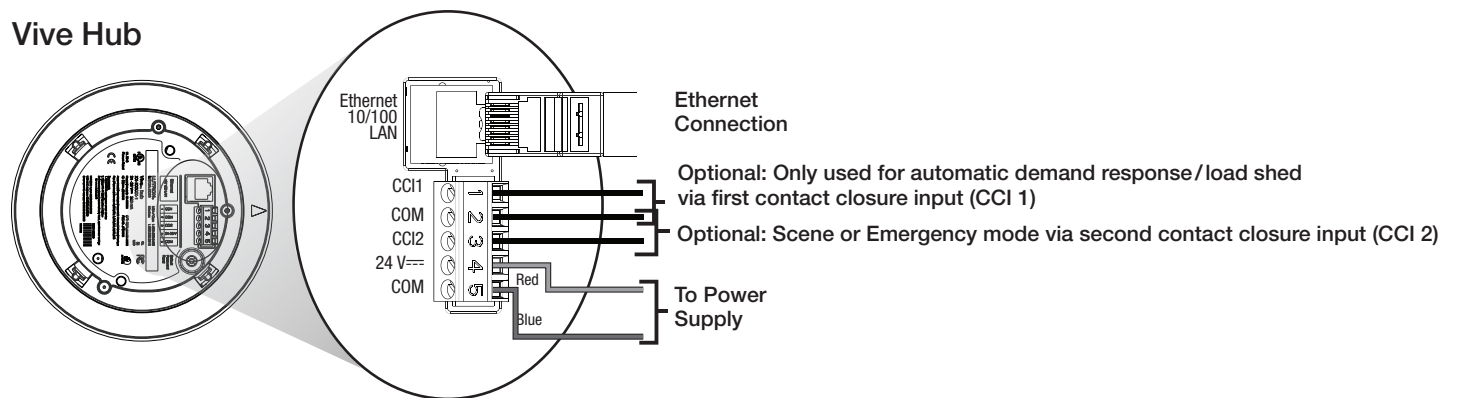

Job Name:	Model Numbers:	
<input type="text"/>	<input type="text"/>	<input type="text"/>
Job Number:	<input type="text"/>	<input type="text"/>

Vive Security Statement

Lutron takes the security of the Vive Lighting Control System very seriously.

The Vive Lighting Control System has been designed and engineered with attention to security since its inception. Lutron has engaged security experts and independent testing firms throughout the entire development of the Vive Lighting Control System. Lutron is committed to security and continuous improvement throughout the Vive product lifecycle.

The Vive Lighting Control System uses a multi-tiered approach to security and National Institute of Standards and Technology (NIST) recommended techniques for security.

They include:

1. An architecture that isolates the wired Ethernet network from the wireless network, which strictly limits the possibility of the Vive Wi-Fi being used to access the corporate network and gain confidential information
2. A distributed security architecture with each hub having its own unique keys that would limit any potential breach to only a small area of the system
3. Multiple levels of password protection (Wi-Fi network and the hubs themselves), with built-in rules that force the user to enter a strong password
4. NIST-recommended best practices including salting and SCrypt for securely storing usernames and passwords
5. AES 128-bit encryption for network communications
6. HTTPS (TLS 1.2) protocol for securing connections to the hub over the wired network
7. WPA2 technology for securing connections to the hub over the Wi-Fi network
8. Azure provided encryption-at-rest technologies

The Vive hub can be deployed in one of two ways:

- Dedicated Lutron Network
- Connected to the corporate IT network via Ethernet. The Vive hub must be connected via Ethernet to access certain features such as BACnet® for BMS integration or OpenADR® integration. Lutron advises following best practices in this instance, including separating the business information network and the building infrastructure network. Use of a VLAN or physically separated networks is recommended for secure deployment.

Dedicated Lutron Network Deployment

The Vive hub is not connected to the building network. Wi-Fi is used to connect to a smart device such as a phone, tablet, or PC for commissioning and configuration only. The Vive hub serves web pages for setup and maintenance via a password-protected connection. The Wi-Fi SSID can be set to not broadcast. The Vive hub Wi-Fi may be disabled if desired.

Corporate IT Network Deployment

The Vive hub may be deployed with a fixed Ethernet IP address or served over DHCP. Once the IT network is operational, the Vive hub will serve password protected web pages for access and maintenance. The Vive hub Wi-Fi may be disabled if desired. The Vive hub reserves the IP subnet 192.168.3.0/24 for its Wi-Fi, so the hub cannot be assigned an Ethernet IP address in that range.

The Vive hub acts as a Wi-Fi access point purely for the configuration and commissioning of the Vive system. It is not a substitute for your building’s normal Wi-Fi access point. The Vive hub does not act as a bridge between wireless and wired networks.

It is strongly recommended that local IT security professionals be involved with the network configuration and set-up to ensure the installation meets their security needs.

Job Name: <input style="width: 90%;" type="text"/>	Model Numbers: <input style="width: 60%;" type="text"/> <input style="width: 30%;" type="text"/>	
Job Number: <input style="width: 150px;" type="text"/>	<input style="width: 300px;" type="text"/>	<input style="width: 300px;" type="text"/>

Dedicated Network

Wi-Fi Only

Ports Used

- No IT configuration needed



Corporate Network

Single Hub

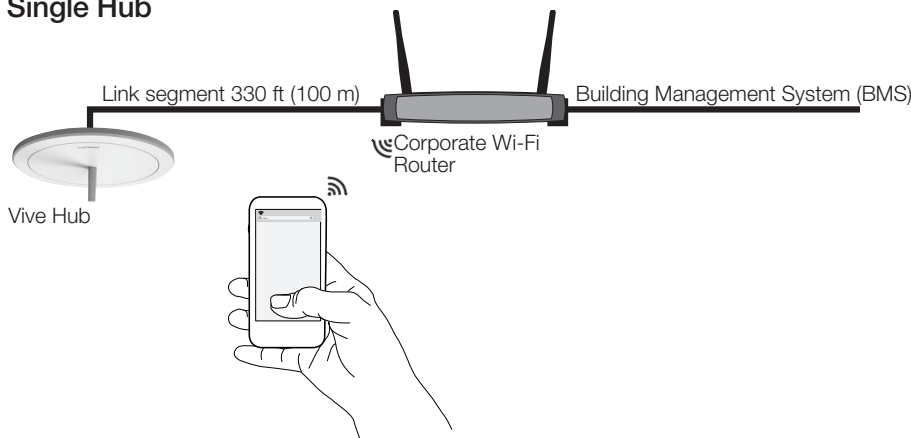

Ports Used

Traffic	Port	Type	Connection	Description
Outbound	47808 (configurable)	UDP	Ethernet	Used for BACnet® integration into Building Management Systems
	80	TCP		Used to discover the Vive hub when mDNS is not available
	5353	UDP	Ethernet	Used to discover the Vive hub via mDNS
	Configurable	TCP	Ethernet	Used for OpenADR®. Specified by utility company
Inbound	443	TCP	Both Ethernet and Wi-Fi	Used to serve user interface to smart device
	80	TCP		Used by other Vive hubs to proxy
	8081	TCP	Ethernet	Used for local LEAP connections to integrations and Vive Vue
	8083	TCP	Ethernet	Used for local LAP connections to integrations and Vive Vue
	8444	TCP	Ethernet	Used to communicate with the Vive Vue server
	47808 (configurable)	UDP	Ethernet	Used for BACnet® integration into Building Management Systems
	5353	UDP	Ethernet	Used to discover the Vive hub via mDNS

Job Name: <input type="text"/>	Model Numbers: <input type="text"/>	
Job Number: <input type="text"/>	<input type="text"/>	<input type="text"/>

Corporate Network (continued)

Multiple Hubs

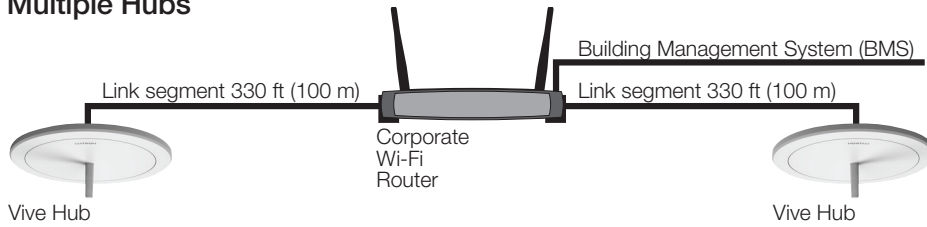

Ports Used

Traffic	Port	Type	Connection	Description
Outbound	47808 (configurable)	UDP	Ethernet	Used for BACnet® integration into Building Management Systems
	80	TCP		Used to discover the Vive hub when mDNS is not available
	5353	UDP	Ethernet	Used to discover the Vive hub via mDNS
	Configurable	TCP	Ethernet	Used for OpenADR®. Specified by utility company
Inbound	443	TCP	Both Ethernet and Wi-Fi	Used to serve user interface to smart device
	80	TCP		Used by other Vive hubs to proxy
	8081	TCP	Ethernet	Used for local LEAP connections to integrations and Vive Vue
	8083	TCP	Ethernet	Used for local LAP connections to integrations and Vive Vue
	8444	TCP	Ethernet	Used to communicate with the Vive Vue server
	47808 (configurable)	UDP	Ethernet	Used for BACnet® integration into Building Management Systems
	5353	UDP	Ethernet	Used to discover the Vive hub via mDNS

Inter-Hub Link Wiring

Notes

- The inter-hub wiring is considered IEC PELV/NEC® Class 2; do not run in the same conduit as line (mains) voltage wiring.
- Wiring distance for any single link segment is 330 ft (100 m) max; use Lutron-provided or third-party Ethernet switches for longer distances (see page 3).
- Up to 64 hubs can be networked together.
- Up to 100 hubs can be networked together when Vive Vue is used.
- Hubs communicate over the inter-hub link using multicast UDP or TCP; a dedicated network is recommended but not required.
- The Wi-Fi access port cannot be used to create an ad hoc network for use as the inter-hub communication link.

Job Name: <input type="text"/>	Model Numbers: <input type="text"/>	
Job Number: <input type="text"/>	<input type="text"/>	<input type="text"/>

Compatible Devices

- **Maestro Wireless Dimmers and Switches**
 - MRF2S-6CL-XX¹
 - MRF2S-6ELV120-XX¹
 - MRF2S-8S-DV-XX¹
 - UMRF2S-8S-DV-XX¹
 - MRF2S-8ANS120-XX¹
 - UMRF2S-8ANS120XX¹
 - MRF2S-6ANS-XX¹
 - MRF2S-6ND-120-XX¹
- **Maestro Wireless Companion Dimmers and Switches**
 - MA-R-XX¹
 - MSC-AD-XX¹
 - MA-AS-XX¹
 - MSC-AS-XX¹
- **Maestro Wireless 0-10V Dimmers and Switches with Sensor²**
 - MRF2S-8SD010-XX
 - MRF2S-8SS-XX
 - MRF2S-8SDV010-XX
 - MRF2S-8SSV-XX
- **PowPak Modules**
 - FCJS-010
 - FCJS-010-EM
 - FCJS-ECO
 - FCJS-ECO-EM
 - RMJS-ECO32-SZ
 - RMJS-8T-DV-B
 - RMJS-8T-DV-B-EM
 - URMJS-8T-DV-B
 - RMJS-16RCCO1DV-B
 - URMJS-16RCCO1DVB
 - RMJS-16R-DV-B
 - RMJS-16R-DV-B-EM
 - URMJS-16R-DV-B
 - RMJS-5RCCO1-DV-B
 - RMJS-5R-DV-B
 - RMJS-20R-DV-B
 - RMJS-20RCCO1DV-B
 - RMJS-CCO1-24-B
 - URMJS-CCO1-24B
 - RMJS-OT-DV
- **In-Line Phase Control Dimmers^{3,4}**
 - RMQS-250-NE
 - RMQS-250-NE-EM4
- **Dimming Modules**
 - RMJS-5T-347
 - RMJS-5T-347-EM
 - RMJS-PNE-DV⁵
 - RMJS-PNE-DV-EM⁵

¹ "XX" denotes color code and "YYY" denotes button marking code.

² Requires Vive hub software 01.09 or higher.

³ Requires Vive hub software 01.12 or higher.

⁴ Israel and Hong Kong only.

⁵ Requires Vive hub software 01.13 or higher.

Job Name: <input style="width: 90%; height: 20px;" type="text"/>	Model Numbers: <input style="width: 95%; height: 20px;" type="text"/>	
Job Number: <input style="width: 80%; height: 20px;" type="text"/>	<input style="width: 95%; height: 20px;" type="text"/>	<input style="width: 95%; height: 20px;" type="text"/>

Compatible Devices (continued)

• **Pico Wireless Controls**¹

- PJ2-2B-GXX-YYY
- PJ2-2BRL-GXX-YYY
- PJ2-3B-GXX-YYY
- PJ2-3BRL-GXX-YYY
- PJ2-4B-GXX-EL1²
- PJ2-4B-GXX-EL2²
- PJ2-4B-GXX-L01²
- PJ2-4B-GXX-L21²
- PJ2-4B-GXX-L31²
- PJ2-4B-GXX-PY4²
- PJ2-P2B-GXX
- PJN-2B-GXX-L01
- PJN-3BRL-GXX-L01
- PQ2-2B-TXX-L01³
- PQ2-2BRL-TXX-L01³
- PQ2-3B-TXX-L01³
- PQ2-3BRL-TXX-L01³
- PQ2-4B-TXX-L21P^{2,3}
- PQ2-4B-TXX-L01^{2,3}
- PQ2-4B-TXX-L31^{2,3}
- PQ2-4B-GXX-EL1^{2,3}
- PQ2-4B-GXX-EL2^{2,3}
- PQ2-4B-GXX-PY4^{2,3}
- PJJ-2B-GXX-YYY
- PJJ-2BRL-GXX-YYY
- PJJ-3BRL-GXX-YYY

• **Wireless Occupancy and Daylight Sensors**

- LRF2-OCR2B-P-WH
- LRF2-VCR2B-P-WH
- LRF2-OHLB-P-WH
- LRF2-OKLB-P-WH
- LRF2-OWLB-P-WH
- LRF2-VHLB-P-WH
- LRF2-VKLB-P-WH
- LRF2-VWLB-P-WH
- LRF2-DCRB-WH
- LRF7-OCR2B-P-WH³
- LRF7-OHLB-P-WH³
- LRF7-OKLB-P-WH³
- LRF7-OWLB-P-WH³
- LRF7-DCRB-WH³

• **Energy Retrofit Kits**

- MRF2S-1S8A-1OC
- MRF2S-1S8A-1OH
- MRF2S-1S8A-1OK
- MRF2S-1S8A-1OW
- MRF2S-1S8A-1VC
- MRF2S-2S8A-1OW

• **Wireless Receptacle Controls**

- CAR2S-15-STR-XX¹
- CAR2S-20-STR-XX¹
- CAR2S-15-DTR-XX¹
- CAR2S-20-DTR-XX¹

• **Wireless Fixture Controls**

- DFCSJ-OEM-RF
- DFCSJ-OEM-OCC
- DFC-OEM-DBI

¹ "XX" denotes color code and "YYY" denotes button marking code.

² Button programming is only for all devices paired to the Pico remote control. These Pico remote controls are unable to have their buttons be individually assigned to different rooms.

³ Israel and Hong Kong only.

Lutron, Clear Connect, Maestro, Maestro Wireless, Pico, PowPak, Radio Powr Savr, Vive Vue, Vive, and any related trade dress and logos are trademarks or registered trademarks of Lutron Electronics Co., Inc. in the US and/or other countries.
Bonjour, Mac, Safari and iPhone are trademarks of Apple Inc., registered in the U.S. and other countries.
App Store is a service mark of Apple Inc., registered in the U.S. and other countries.
All other product names, logos, and brands are property of their respective owners.

Job Name: <input type="text"/>	Model Numbers: <input type="text"/>	
Job Number: <input type="text"/>	<input type="text"/>	<input type="text"/>