

EZ-MAX™ H SERIES - Lighting Control Panel Relays

Cat. No. RELAY



WARNINGS:

- **TO AVOID FIRE, SHOCK OR DEATH: TURN OFF POWER AT CIRCUIT BREAKER OR FUSE AND TEST THAT THE POWER IS OFF BEFORE WIRING!**
- **TO AVOID PERSONAL INJURY OR PROPERTY DAMAGE, DO NOT** install to control a receptacle, or a load in excess of the specified rating.
- Always disconnect the power supply from the panel's main board prior to making any connections between relay boards and the main board. Failure to do so, may result in personal injury, damage to the panel, and void its warranty.
- To be installed and/or used in accordance with electrical codes and regulations.
- Must be installed by electrician or other qualified personnel.
- A disconnect switch or a circuit breaker must be provided and marked as the disconnecting device.
- The use of accessory equipment, not recommended by the manufacturer, may cause an unsafe condition.

CAUTIONS:

- If any emergency circuits are fed or controlled from this panel, they must be located electrically where fed. For example, from a UPS, generator, or other guaranteed power source during emergency and power outage situations.
- If the equipment is used in a manner not specified by the manufacturer, the protection provided by the equipment may be impaired.
- For indoor use only.
- **DO NOT** mount near gas or electric heaters.
- No user serviceable components. **DO NOT** attempt to service or repair.
- Use this device **WITH COPPER OR COPPER-CLAD WIRE ONLY.**

PK-A3453-10-00-0A

INSTALLATION INSTRUCTIONS

ENGLISH

Product Description

H Series' relays are designed to be installed in EZ-MAX H Series panels only. Individual relays of any type can be placed in any position in the panel. Two pole relays fit in the same space as one pole relays.

Installing Individual Relay Cards

WARNING: TO AVOID FIRE, SHOCK OR DEATH, turn OFF power at circuit breaker or fuse and test that the power is off before wiring.

1. Disconnect the low voltage control input plug, which is located at the top of the main board.
2. Align the relay board in the desired relay position and insert the relay card plug connector (male) into the socket (female) on the main board.

NOTE: Make sure all of the pins line up, and the connection is tight.
3. Insert and tighten the relay card mounting screw.

NOTE: Do not over tighten the relay card mounting screw with a high-amount of torque force, as this can loosen the relay card plug connector.

EZ-MAX H Series Panel Interior

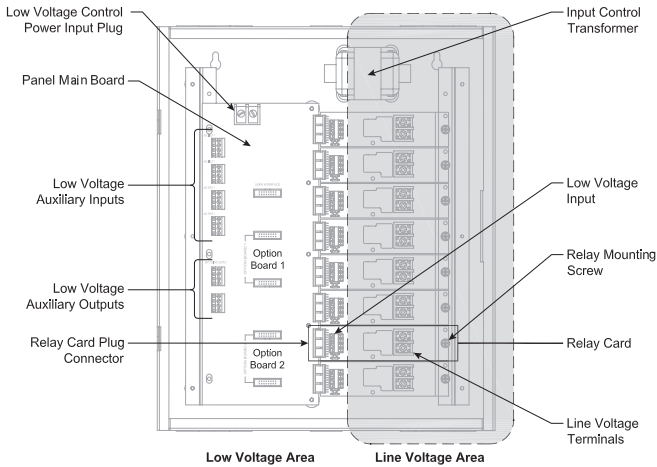

Connecting Lighting Loads

CAUTION: Prior to making any connections to the relay outputs, verify that none of the loads have shorted. Failure to do so, may result in personal injury, damage to the panel, and void its warranty.

1. Turn the power OFF.
2. Route the lighting system line and load leads through the high-voltage area of the panel.
3. Connect line and load leads for each lighting load to the output terminals of the appropriate relay, as delineated in the project plans or panel load schedule. Space is provided for the circuit identification number to be written adjacent to the terminals on each relay card.

NOTE: If no panel load schedule exists, use the panel load schedule form supplied in the clear plastic pocket inside the panel door to record the lighting circuit relay assignments, while connecting the relay.

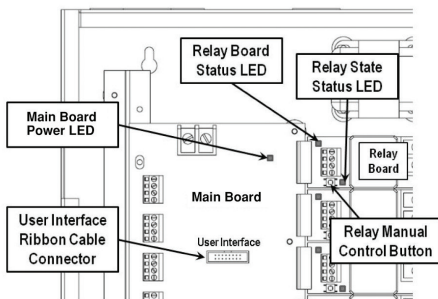

Connecting Low Voltage Input

Bring the low-voltage wiring for the contact inputs in through the knockouts in the low-voltage wiring area. The EZ-MAX H Series relay card includes one input. The input is software, which you can configure via programming to support momentary switches, maintained switches (latching), motion sensors, or photocells. The input may be connected prior to programming. Inputs may be connected to any terminal location, regardless of final control programming. Connect contact closure input devices to the input terminals using #18 AWG wire.

NOTE: Use the panel load schedule form, supplied in the clear plastic pocket inside the panel door, to record the low voltage input types while making connections.

The Low Voltage Control diagrams, shown below, are for use with Leviton low-voltage input devices ONLY.

Photocell

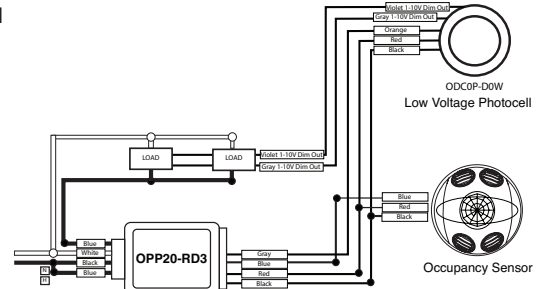

Occupancy Sensor

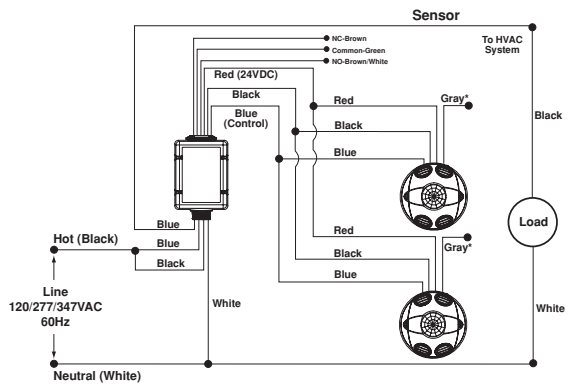

Low Voltage Switch

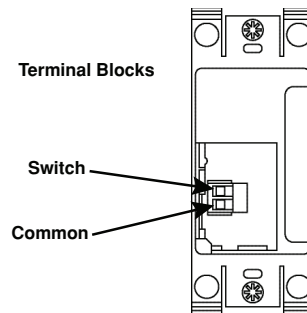

Low Voltage Switch with LED

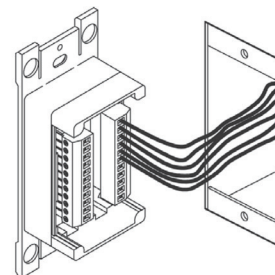

Relay Specifications

Characteristics		Load Ratings					SCCR
Type	Poles	VAC	Tungsten	Elec. Ballast	Magnetic Ballast	Motor Rating	
RELAY-L3H Latching	1	120	20A	16A	30A	1 HP	18 kA
		277	N/A	16A	30A	N/A	
		347	N/A	20A	N/A	N/A	
RELAY-2PH Elec. Held, N.O.	2	208	N/A	N/A	20A	2 HP	14 kA
		240					
		480					

General Specifications

Type	Description
Operating Voltages	RELAY-L3H: 120V, 277V, 347V AC (50/60 Hz) RELAY-2PH: 208V, 240V, 480V AC (50/60 Hz)
Class 2 Output Rating	8-Relay: 24VDC, 150mA (Max. 300mA) 24-Relay: 24VDC, 150mA (Max. 900mA)
Class 2 Terminal	Wire Size: 14, 16, 18, 20, 22 AWG Recommended Tightening Torque: 0.45 N-m (4 in-lb)
Status Indicators	Green: Indicates relay is in the closed position. Red: Depends on the input that is programmed.
Operating Environment	32°-112°F (0°-50°C) Relative humidity (non-condensing): 10%-90%
Inrush Withstand	500 A @ 2 ms
Dimensions	1.635" W x 5.5" L (41.28 mm W x 139.7 mm L)
Mounting	Mounts inside an EZ-MAX H Series panel Pre-drilled mounting hole for securing relay card Individual relay cards - 1P and 2P are equal size
Control Input Device Types	Low-voltage switches - Momentary or maintained style, Pilot light indicator support Occupancy sensor - Three-wire, 24VDC Daylight sensor -Three-wire 24VDC

What to do if...

A blinking green relay board status LED indicates that communication has not been properly established for this card.

- Power down the panel.
- Remove the relay card. Make sure the connectors on the relay card and on the main board are not damaged.
- Reinstall the relay card.
- Power up the panel, see if the LED light stopped blinking, and verify the relay card can be seen through the controller.

The relay does not turn ON.

- If the load was removed, check the continuity of the relay terminal blocks.
 - If the green relay board status LED is ON, make sure there is resistance.
 - If the green relay board status LED is OFF, make sure there is no resistance.
- Verify the supply breaker is ON and energized.
- The relay contact may be damaged.

The relay does not turn OFF the load.

- If the load was removed, check the continuity of the relay terminal blocks.
 - If the green relay board status LED is ON, make sure there is resistance.
 - If the green relay board status LED is OFF, make sure there is no resistance.
- Relay contact may have been welded shut.
- Circuit from supply breaker may be wired in parallel to load.

FCC STATEMENT

This equipment has been tested and found to comply with the limits for a Class B digital device, pursuant to part 15 of the FCC Rules. These limits are designed to provide reasonable protection against harmful interference in a residential installation. This equipment generates, uses and can radiate radio frequency energy and, if not installed and used in accordance with the instructions, may cause harmful interference to radio communications. However, there is no guarantee that interference will not occur in a particular installation. If this equipment does cause harmful interference to radio or television reception, which can be determined by turning the equipment off and on, the user is encouraged to try to correct the interference by one or more of the following measures:

- Reorient or relocate the receiving antenna.
- Increase the separation between the equipment and receiver.
- Connect the equipment into an outlet on a circuit different from that to which the receiver is connected.
- Consult the dealer or an experienced radio/TV technician for help.

IC STATEMENT

This device complies with Industry Canada licence-exempt RSS standard(s). Operation is subject to the following two conditions: (1) this device may not cause interference, and (2) this device must accept any interference, including interference that may cause undesired operation of the device.

FCC SUPPLIERS DECLARATION OF CONFORMITY (sDoC): RELAY product with responsible party Leviton Manufacturing, Inc., 201 N Service Road, Melville, NY, www.Leviton.com. This device complies with part 15 of the FCC Rules. Operation is subject to the following two conditions: (1) This device may not cause harmful interference, and (2) this device must accept any interference received, including interference that may cause undesired operation.

Any changes or modifications not expressly approved by Leviton Manufacturing Co., could void the user's authority to operate the equipment.

LEVITON, the Leviton logo, and EZ-MAX are trademarks of Leviton Manufacturing Co., Inc.

Patents covering this product, if any, can be found on www.leviton.com/patents.

FOR CANADA ONLY

For warranty information and/or product returns, residents of Canada should contact Leviton in writing at **Leviton Manufacturing of Canada ULC** to the attention of the **Quality Assurance Department, 165 Hymus Blvd, Pointe-Claire (Quebec), Canada H9R 1E9 or by telephone at 1-800-405-5320.**

LIMITED 5 YEAR WARRANTY AND EXCLUSIONS

Leviton warrants to the original consumer purchaser and not for the benefit of anyone else that this product at the time of its sale by Leviton is free of defects in materials and workmanship under normal and proper use for five years from the purchase date. Leviton's only obligation is to correct such defects by repair or replacement, at its option. **For details visit www.leviton.com or call 1-800-824-3005.** This warranty excludes and there is disclaimed liability for labor for removal of this product or reinstallation. This warranty is void if this product is installed improperly or in an improper environment, overloaded, misused, opened, abused, or altered in any manner, or is not used under normal operating conditions or not in accordance with any labels or instructions. **There are no other or implied warranties of any kind, including merchantability and fitness for a particular purpose,** but if any implied warranty is required by the applicable jurisdiction, the duration of any such implied warranty, including merchantability and fitness for a particular purpose, is limited to five years. **Leviton is not liable for incidental, indirect, special, or consequential damages, including without limitation, damage to, or loss of use of, any equipment, lost sales or profits or delay or failure to perform this warranty obligation.** The remedies provided herein are the exclusive remedies under this warranty, whether based on contract, tort or otherwise.

For Technical Assistance Call: 1-800-824-3005 (USA Only) or 1-800-405-5320 (Canada Only) www.leviton.com