

INSTALLATION INSTRUCTIONS

REC-DMX-5A-4Z



⚠ WARNING

These products may represent a possible shock or fire hazard if improperly installed or attached in any way. Products should be installed in accordance with these instructions, current electrical codes, and/or the current National Electric Code (NEC).

⚠ WARNING

This receiver requires a 12-36V DC power supply (LED-DR series driver recommended, sold separately). Disconnect supply power at the source prior to installation.

SAFETY INFORMATION

- Read all instructions before beginning; Save these instructions for future use.
- To reduce the risk of fire, electric shock, or injury to person(s), pay close attention to this manual and stay within its guidelines when using this product.
- This receiver is rated IP20; avoid the sun and moisture.
- Avoid using receiver in areas where extreme hot, cold, dust, or humidity exist.
- This receiver is suitable for indoor, dry locations only.
- Always be sure to mount this controller in an area with proper ventilation to avoid overheating.
- This product has an operating temperature range of -20°C to 50°C.
- Never connect any cables while power is on and always ensure correct connections to avoid short circuits prior to switching on. Ensure all wires and cables are secured tightly in the connector prior to operation.
- For cleaning, use a soft, dry or damp cloth. Do not use harsh chemicals or abrasives.
- This receiver is rated for 12-36V DC input with a maximum line-in of 20.5A.
- This receiver has 4 output terminals rated for 5A/60-180W each.

INSTALLING RECEIVER (SEE FIGURE 1):

This receiver requires a 12-36V DC power supply (12V DC or 24V DC LED-DR series driver recommended, sold separately). This receiver requires a Trulux DMX controller (sold separately) or another auxiliary DMX master control (not included).

1. Determine desired location of receiver. Mounting tabs on either end of the receiver may be utilized to secure receiver in place via screws.
2. This receiver has 4 x 5A current output terminals that can be used with single color, Tunable CCT, RGB, and RGB+WW fixtures. Wire the receiver to a fixture by following the fixture’s instructions manual and wiring diagrams, ensuring to match polarity (wiring varies depending on product). Connect fixture prior to bringing any power to the system.
3. Bring 12-36V DC supply power to the receiver, matching polarity (See Figure 1).

FIGURE 1

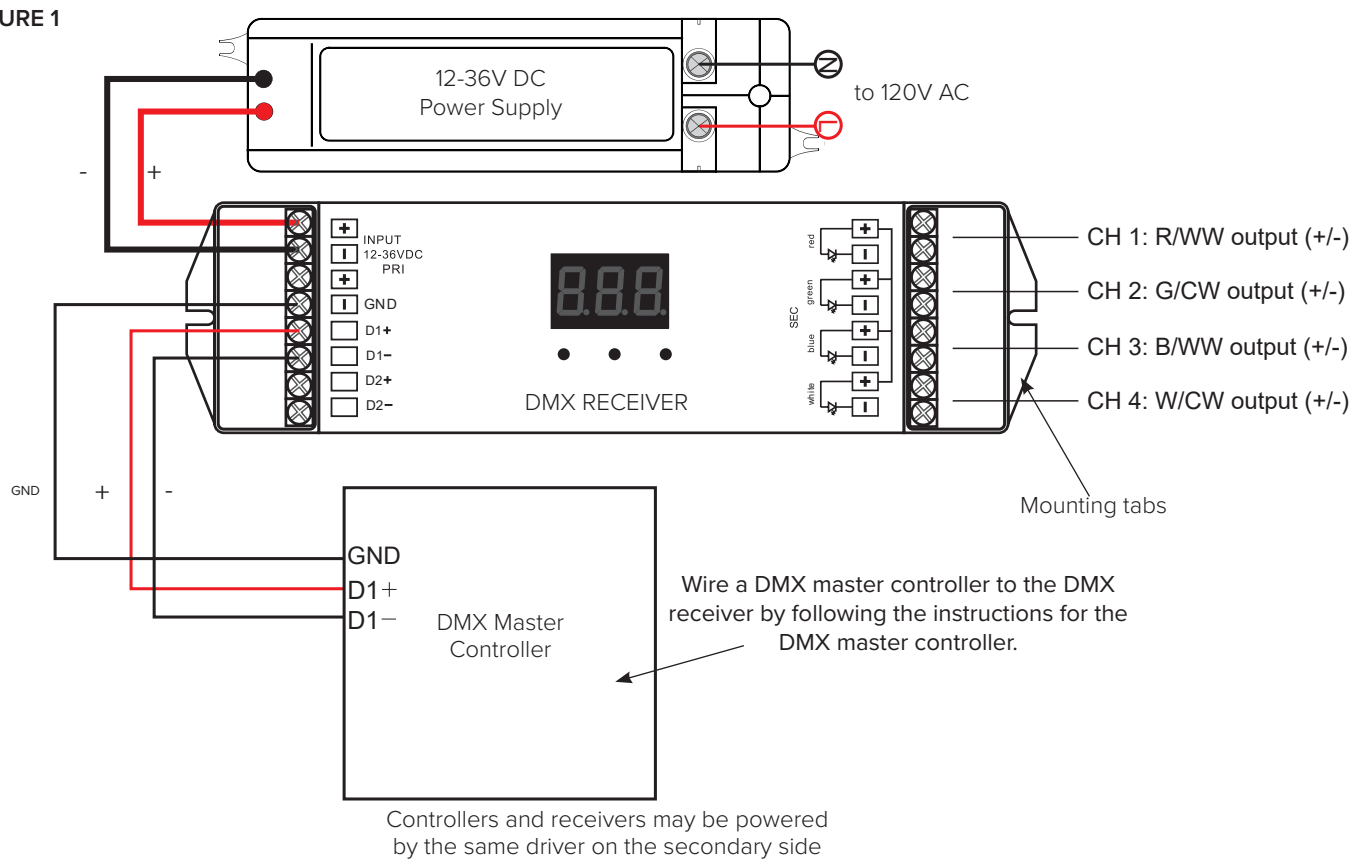

INSTALLATION INSTRUCTIONS

REC-DMX-5A-4Z



INTERCONNECTING RECEIVERS (SEE FIGURE 2):

This receiver requires a 12-36V DC power supply (LED-DR series driver recommended, sold separately). This receiver requires a Trulux DMX controller (sold separately) or another auxiliary DMX master control (not included).

- Interconnect DMX signal by connecting D2 (+ and -) from first controller to D1 (+ and -) on second controller, then connect ground to ground on each. Continue for each successive controller. See Figure 2.
Note: D1 (+ and -) on first controller in series will be utilized by master DMX controller (sold separately). See Figure 1 on previous page.
- Bring 12-36V DC supply power to each receiver in succession, matching polarity. See Figure 2.

OPERATING DMX RECEIVER (SEE FIGURE 3):

This receiver requires a 12-36V DC power supply (LED-DR series driver sold separately). This receiver requires a Trulux DMX controller (sold separately) or another auxiliary DMX master control (not included).

- To set channels, press and hold buttons 2 and 3 (see Figure 3) simultaneously for 2 seconds until the digital display flashes. Use button 1 to select either 1, 2, 3, or 4 channels. Press and hold any button for 2 seconds to confirm channels. Factory default is set at 4 channels.
For example:

1	2	3	4
001	002	003	004

- To set the DMX address, press and hold button 1 (see Figure 3) for 2 seconds until the digital display flashes. Use button 1 to select address, then press and hold any button for 2 seconds to confirm.
- To choose PWM frequency, press and hold buttons 1 and 3 (see Figure 3) simultaneously for 2 seconds until the digital display flashes to show P-c.
P = PWM Frequency: Press button 1 to toggle between "1" (1500Hz) and "2" (200Hz).
Note: When dimming with PWM, the LEDs will be cycling between 'on' and 'off' states. To reduce flicker, opt for higher frequencies to ensure the LED modulation is not observable to the human eye.
C = Dimming options: Press button 3 to toggle between "1" (logarithmic dimming) and "2" (linear dimming)
Note: For DMX control, utilize "1" for logarithmic dimming

FCC Compliance Statement

This device complies with part 15 of the FCC Rules. Operation is subject to the following two conditions:

- This device may not cause harmful interference, and
- This device must accept any interference received, including interference that may cause undesired operation.

FCC WARNING

This equipment has been tested and found to comply with the limits for a Class B digital device, pursuant to Part 15 of the FCC Rules. These limits are designed to provide reasonable protection against harmful interference in a residential installation. This equipment generates, uses and can radiate radio frequency energy and, if not installed and used in accordance with the instructions, may cause harmful interference to radio communications. However, there is no guarantee that interference will not occur in a particular installation. If this equipment does cause harmful interference to radio or television reception, which can be determined by turning the equipment off and on, the user is encouraged to try to correct the interference by one or more of the following measures:

- Reorient or relocate the receiving antenna.
- Increase the separation between the equipment and the receiver.
- Connect the equipment into an outlet different from that to which the receiver is connected.
- Consult the dealer or an experienced radio/TV technician for help.

FIGURE 2

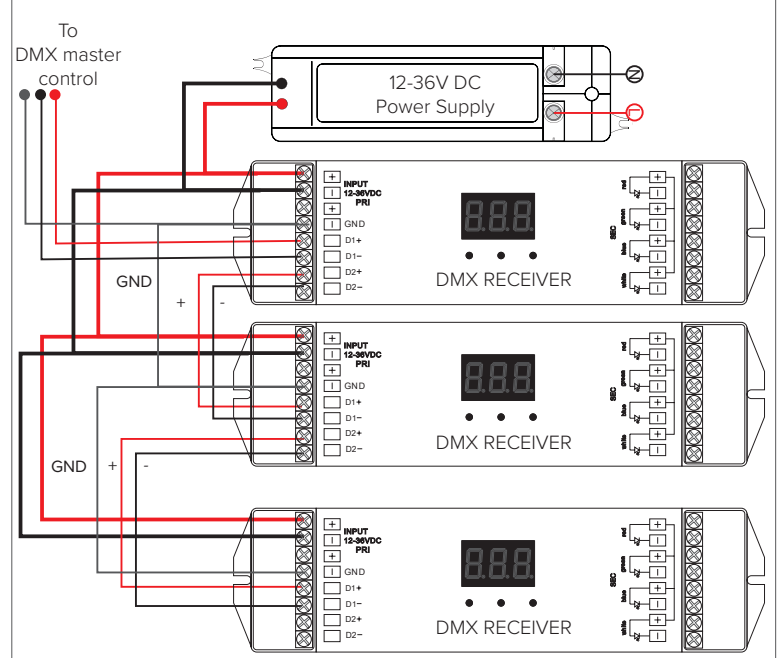

FIGURE 3

