

# Lumina™ RF Wireless Occupancy Sensor

Cat. Nos. ZSC04 & ZSC15

PK-A3251-10-00-0A

## INSTALLATION AND QUICK START SHEET

ENGLISH

### WARNINGS

- **TO AVOID FIRE, SHOCK OR DEATH, DO NOT RECHARGE, DISASSEMBLE OR INCINERATE BATTERY, NOR HEAT IT ABOVE 100° C (212° F).** Dispose of used battery promptly. DO NOT dispose of battery in normal household waste. Keep away from children. Please contact your local waste provider or recycling facility for proper disposal of used battery.

### COMPATIBLE DEVICES

- Lumina™ gateway
- Lumina™ RF Room Controller

### NOTES

- Requires Lumina™ gateway or Lumina™ RF Room Controller for programming and control communication to other devices.
- Do not mount the sensor until after it has been programmed to communicate with all appropriate receivers.

### DESCRIPTION

This sensor is primarily intended to be powered via battery, however, it may be powered by at +24VDC supply, ex: OPB15, OSP20. When powering from an external source, the battery must be removed and discarded, and SLI24-000 jumper should be used to connect to the 24V supply.

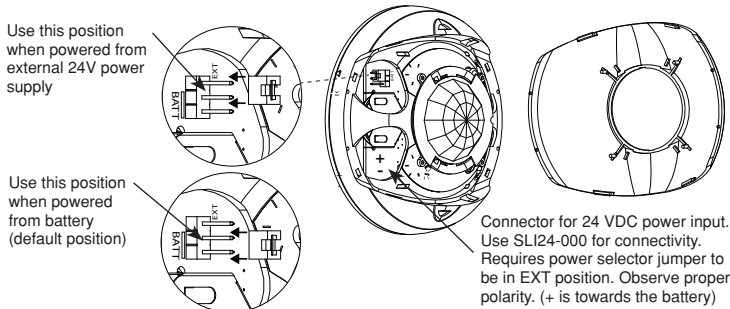

The occupancy sensor is a 2.4GHz wireless communication device which transmits a wireless message to the Lumina™ gateway or Lumina™ RF Room Controller. This communication occurs each time an occupancy change occurs in a room, occupied to unoccupied or unoccupied to occupied. The gateway/controller then routes the message to the load control device to take assigned action. Occupancy/Vacancy time delays are configured and maintained in the controller and load control devices; this improves the design and efficiency of the wireless system.

### QUICK START: ENROLLMENT, FACTORY DEFAULT, AND VERIFICATION

**NOTE: Remove "Battery Pull Tab" to activate device.**

**Make sure the sensor is within 16 feet (5 meters) of the desired receiver when programming.**

#### • To enroll device to network:

Press and hold green button for 10 seconds until LED indicator blinks amber. On release, LED indicator will blink green rapidly indicating start of join process. On successful enrollment, LED indicator will blink green 3 times.

#### • To factory reset device:

**NOTE:** If green button is pressed for more than 25 seconds, the indicator times out and no functions are performed.

Press and hold green button for 20 seconds. Amber LED will start blinking once every two seconds between 10 and 20 seconds, then, at 20 seconds start blinking rapidly. When LED starts blinking rapidly, release.

LED indicator will blink green 5 times when reset process is completed successfully.

### CAUTIONS

- Replace battery with Panasonic, Energizer, Sony, Duracell, Rayovac or Maxell CR2450 only. Use of another battery may present a risk of fire or explosion.
- To be installed and/or used in accordance with appropriate electrical codes and regulations.
- If you are unsure about any part of these instructions, consult an electrician.
- For indoor applications only.
- Save these instructions.

#### • To verify device enrollment status:

Press green button

LED indicator will blink green 3 times if network enrollment is successful

LED indicator will blink red 2 times if network enrollment is incomplete

LED indicator will blink red 1 time if no network is enrolled

### OPERATION

#### LED Indicator

The Lumina™ RF occupancy sensor uses a LED indicator that flashes red to indicate proper occupancy status. This LED is also used during programming.

### OPERATION TESTING

1. Once joined into a network, confirm occupancy detection (RED LED will blink), then cover the occupancy sensor so no further detection is detected.
  - a. Verify timeout and load turns OFF accurately
2. Uncover the occupancy sensor to verify Auto-ON responds and energizes load(s).

### FIELD OF VIEW & SENSITIVITY TESTING

- Perform a FOV walk test of the coverage area and confirm the RED LED blinks and detects within the responsible space.
- Adjust the sensitivity POT as necessary to increase or decrease the detection sensitivity within the field of view.

**PIR SENSITIVITY ADJUSTMENT:** This can increase or decrease the sensitivity within the field of view. Use the red knob to increase or decrease sensitivity. When complete, **push the green button** to save the setting.

### INSTALLATION

**Do not mount the sensor until after it has been programmed to communicate with all appropriate receivers. Equipment needed for installation:**

- Ceiling Tile Stem, Nut, & Washer (included)
- Double Sided Foam Mounting Tape (included)
- Screws (included) with Wall Anchors (not included)

**Location: (Choose location to mount the sensor and the appropriate method - Tile Stem, Screws, Mounting Tape)**

1. Sensor location is very important to ensure correct operation within each unique space.
2. Improve performance to Auto-ON response and reduce risk of false tripping from external motion (example: hallway traffic) by choosing the best location.
3. Do not locate a sensor on a mounting surface within 6 feet of - air ducts, moving machinery, heat sources.
4. Included PIR shields can be used to decrease field of view. 180° shield is provided, and a full shield is provided which can be cutout to your specific needs.

Sensor location optimized for best entry detection and reduced nuisance tripping from hallway

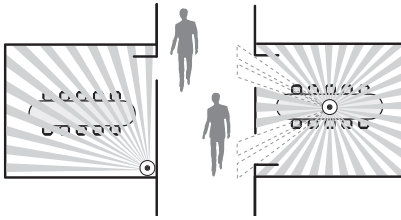

Sensor location center of room has potential risk of nuisance tripping from hallway traffic

#### CEILING TILE MOUNT

1. Use the included ceiling tile stem, connect the stem to the back cover and twist to secure, reference figures below for details.
2. In desired location, press the ceiling tile stem through the ceiling tile and install the washer and nut above the ceiling tile to secure.

**NOTE: The sensor back cover and front body are keyed with arrows for ease of separation. To lock the sensor body to the back cover, align arrows and press back cover to the front body, then rotate until the arrows are not aligned.**

3. Rotate the sensor to the desired orientation.

**Mounting Option Diagram A**  
Sensor Mounted to Drop Ceiling Using Tile Stem

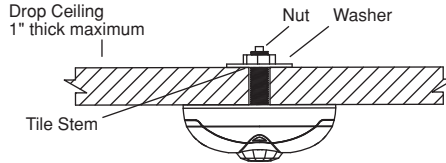

#### SURFACE MOUNT USING SCREWS

1. To remove the back cover of the sensor, locate alignment arrow on the edge of the back cover and on the edge of the front body, rotate the back cover and front body until the two arrows line up and pull apart.
2. Install back cover of the ceiling sensor to desired location using the included screws (nuts and washers), or screws in combination with commercially available wall anchors. If necessary, drill pilot holes.
3. Secure the sensor body to the back cover by aligning the arrows. Lock it by turning the sensor such that the arrows do not line up.
4. Rotate the sensor to the desired orientation.

**Mounting Option Diagram B**  
Sensor Mounted to Wallboard or Drop Ceiling Using Screws

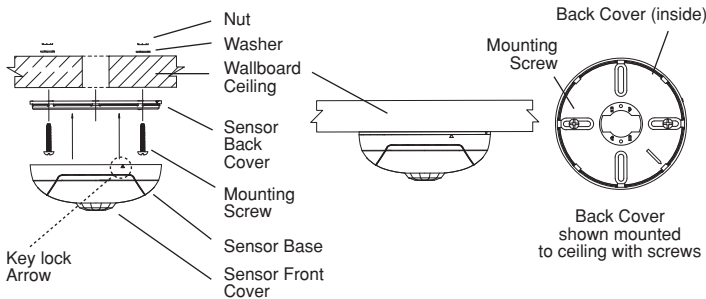

#### FCC COMPLIANCE STATEMENT:

Contains FCC ID: W7Z-ZICM357SP0

The enclosed device complies with Part 15 of the FCC Rules. Operation is subject to the following two conditions:

(i.) This device may not cause harmful interference (ii.) This device must accept any interference received, including interference that may cause undesired operation. Any changes or modifications not expressly approved by Leviton could void the user's authority to operate this equipment. This equipment has been tested and found to comply with the limits for a Class B digital device, pursuant to part 15 of the FCC Rules. These limits are designed to provide reasonable protection against harmful interference in a residential installation. This equipment generates uses and can radiate radio frequency energy and, if not installed and used in accordance with the instructions, may cause harmful interference to radio communications. However, there is no guarantee that interference will not occur in a particular installation. If this equipment does cause harmful interference to radio or television reception, which can be determined by turning the equipment off and on, the user is encouraged to try to correct the interference by one or more of the following measures:

- Reorient or relocate the receiving antenna.
- Increase the separation between the equipment and receiver.
- Connect the equipment into an outlet on a circuit different from that to which the receiver is connected.
- Consult the dealer or an experienced radio/TV technician for help.

#### RF EXPOSURE AND CO-LOCATION:

To comply with FCC OET Bulletin 65 and ISED RF exposure limits for general population / uncontrolled exposure this device should be installed and operated with a minimum distance of 7.9 inches (20 cm) between the radiator and your body. This transmitter must not be co-located or operated in conjunction with any other antenna or transmitter.

**FOR CANADA ONLY:** For warranty information and/or product returns, residents of Canada should contact Leviton in writing at **Leviton Manufacturing of Canada Ltd to the attention of the Quality Assurance Department, 165 Hymus Blvd, Pointe-Claire (Quebec), Canada H9R 1E9** or by telephone at **1 800 405-5320**.

#### SURFACE MOUNT USING TAPE

1. Remove backing material and apply double sided mounting tape to the Sensor Base.
2. Press and hold the Wireless occupancy sensor to the desired mounting surface for a few seconds before releasing. **NOTE:** The sensor back cover and front body are keyed with arrows for ease of separation. To lock the sensor body to the back cover, align arrows and press back cover to the front body, then rotate until the arrows are not aligned.
3. Rotate the sensor to the desired orientation.

#### TROUBLESHOOTING

- Verify red LED is blinking every 15 seconds with occupancy. This indicates the device is working properly and detecting occupancy.
- Separate the device from other noisy electronics (example: personal computers, electronic ballasts, machinery).
- Ensure the RF design is within specified range.
- Ensure that the control devices are located properly to optimize RF design within buildings (example: building construction compared to line of sight).
- Remove the device and re-enroll to the network.
- Reset to factory defaults.

#### PASSIVE INFRARED FIELD OF VIEW

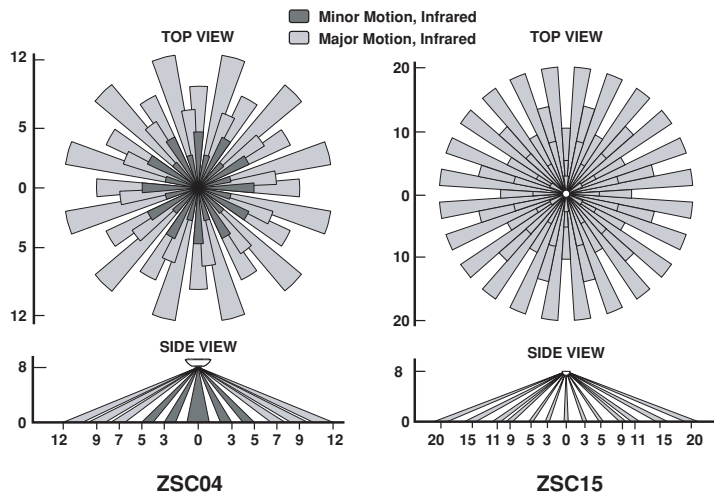

#### INDUSTRY CANADA COMPLIANCE STATEMENT:

Contains IC: 8254A-ZICM357SP0.

This device complies with Industry Canada license-exempt RSS standard(s). Operation is subject to the following two conditions: (1) this device may not cause interference, and (2) this device must accept any interference, including interference that may cause undesired operation of the device.

**IMPORTANT!** Any changes or modifications not expressly approved by the party responsible for compliance could void the user's authority to operate this equipment.

**TRADEMARK DISCLAIMER:** Use herein of third party trademarks, service marks, trade names, brand names and/or product names are for informational purposes only, are/may be the trademarks of their respective owners; such use is not meant to imply affiliation, sponsorship, or endorsement.

#### LEVITON LIMITED WARRANTY

Leviton warrants to the original consumer purchaser and not for the benefit of anyone else that products manufactured by Leviton under the Leviton brand name ("Product") will be free from defects in material and workmanship for the time periods indicated below, whichever is shorter: • **OmniPro II and Lumina Pro:** three (3) years from installation or 42 months from manufacture date. • **OmniIL, Omni II, and Lumina:** two (2) years from installation or 30 months from manufacture date. • **Thermostats, Accessories:** two (2) years from installation or 30 months from manufacture date. • **Batteries:** Rechargeable batteries in products are warranted for ninety (90) days from date of purchase. **Note:** Primary (non-rechargeable) batteries shipped in products are not warranted. **Products with Windows® Operating Systems:** During the warranty period, Leviton will restore corrupted operating systems to factory default at no charge, provided that the product has been used as originally intended. Installation of non-Leviton software or modification of the operating system voids this warranty. Leviton's obligation under this Limited Warranty is limited to the repair or replacement, at Leviton's option, of Product that fails due to defect in material or workmanship. Leviton reserves the right to replace product under this Limited Warranty with new or re-manufactured product. **Leviton will not be responsible for labor costs of removal or re-installation of Product.** The repaired or replaced product is then warranted under the terms of this Limited Warranty for the remainder of the Limited Warranty time period or ninety (90) days, whichever is longer. This Limited Warranty does not cover PC-based software products. **Leviton is not responsible for conditions or applications beyond Leviton's control. Leviton is not responsible for issues related to improper installation, including failure to follow written Installation and operation instructions, normal wear and tear, catastrophe, fault or negligence of the user or other problems external to the Product.** To view complete warranty and instructions for returning product, please visit us at [www.leviton.com](http://www.leviton.com).